

## Public Notice of Regular Meeting of the Pewaukee Public Library Board of Trustees

Pursuant to section 19.84 (2) and (3) of the Wisconsin Statutes, notice is hereby given to the public and to those news media who have filed a written or electronic request for this notice, that the annual meeting of the Pewaukee Public Library Board of Trustees will be held on Wednesday, August 20, 2025 at 6:30 p.m. The meeting will be held in the Visaya Room at the Pewaukee Public Library, 210 Main Street, Pewaukee, WI 53072.

### PEWAUKEE PUBLIC LIBRARY BOARD MEETING - AGENDA Wednesday, August 20 at 6:30 p.m.

As of the date of this notice, the subject matter known to be intended for consideration is as follows:

1. Call Meeting to Order and Roll Call

#### **SPECIAL BUSINESS:**

2. Presentation by Library Services Manager, Emma Kutschenreuter

#### **REGULAR BUSINESS:**

3. Citizen Comments/Correspondence
4. Approval of Consent Agenda
  - a. Minutes July 16, 2025 (Regular Board Meeting)
  - b. Financial Reports:
    - i. GL Budget vs. Actual Library – July 2025
    - ii. GL Detail Library – July 2025
    - iii. Payment Approval Report – July 2025
    - iv. LGIP Statement – July 2025
  - c. Library Monthly Statistics Report though July 2025
  - d. Library Directors Report August 2025

#### **OLD BUSINESS:**

5. Discussion and possible action of the 2026 Joint Library Budget
6. Discussion and possible action on the Library's 5 year Capital Improvement Plan and 2026 Capital Improvement Budget Request

#### **NEW BUSINESS:**

7. Discussion and possible action on the Capital roof replacement and engagement of Garland to prepare the specifications and project management
8. Discussion and information on digital resources for library patrons
9. Discussion and possible action on *TE10: Developing Essential Library Policies*
10. ADJOURNMENT

**NEXT MEETING SCHEDULED: Wednesday, September 17, 2025**

**LOCATION: Visaya Room, Pewaukee Public Library, 210 Main Street, Pewaukee, WI 53072**

The Pewaukee Public Library is committed to providing the highest degree of accessibility within its means when conducting library-sponsored events. Please notify us of your disability-related accommodation requests two weeks prior to a Library Board meeting by calling (262) 691-5670, extension 920. We will attempt to honor all requests but cannot assure that requests made too close to the date will be able to be accommodated.

Posted: Friday, August 15, 2025
---------------------------------

## **Board Presentation – Circulation**

August 2025

Emma Kutschenreuter

### **Summer in Circulation**

This summer, we have seen a much higher number of patron interactions and materials to circulate than the previous few years. We've partnered with two companies to offer temporary work experiences for people with disabilities, a program that has been consistently successful. We recently hired a permanent employee through this initiative.

### **Current and Future Projects**

- **Learning the Job**

- Since I am still somewhat new in my position, I am still working on getting familiar with my different tasks unique to the Library Services Manager role. Madi and Nan are great teachers and have been helping me along the way, but I know I still have more to learn in regards to managing and motivating employees.
- With Nan and Madi's help, as well as trainings and webinars offered by the Bridges Library System and the Wisconsin Library Association, I am confident that I will continue to improve in these areas.

- **Staff**

- In my first few months, I needed to hire and train some new employees, as well as work on covering shifts for employees who left or were out for extended times. I am very appreciative of library and circulation staff for their flexibility in covering shifts while we were understaffed.
- I allocated extra hours to our staff this summer to keep up with the high volume of patron interactions and materials to circulate. This strategy has been effective in maintaining our workflow, allowing me to focus on my own projects.
- For Library Pages especially, Nan and I have been reviewing the budgeted hours in order to have Library Pages work more during busier times and less during slow times. We will continue to do this in the coming months.

- **Pantheon and Goodwill**

- Working with Pantheon and Goodwill to offer work experience to those with disabilities has been extremely rewarding.
- Through these organizations, we have had some extra help shelving at no cost to us that has been a huge help in the busy summer months. Also, the participants of the program are thankful to be able to gain vital work experience in a supportive environment.

- I also hired a Pantheon intern as a permanent Library Page in June. This was very helpful as he was already trained on some of the duties of his new role, which made his onboarding very easy.
- **Circulation of Materials and Back Room Organization**
  - With some new carts and some reorganization in our back-room, circulation of materials has become much smoother.
  - There are more carts available for checked-in materials, so that when a cart is full of materials, it can be shelved right away, instead of materials needing to be moved to another cart to be shelved.
  - Disposing of unused shelves in our back-room area has made things easier to navigate. It also has made more room for full carts so that pages can put them in order and shelve them right away.
- **Launching New Public Catalog - Vega**
  - In September, we will be launching a new public catalog. It offers significant benefits like showing all copies and editions of a title in one “rolled up” entry, so that Pewaukee patrons can easily find out if an item is available at the Pewaukee Library.
  - Previously, some items of the same title were cataloged separately, so patrons would put holds on an item at another library not knowing there was a copy at our library. Ultimately, the new catalog should reduce the number of books we send to other libraries and that other libraries send to us.
  - In anticipation of the change, I am scheduling training sessions with all staff to familiarize them with the new catalog. I have created a training plan and a demo to go through with staff at each training session.
  - I will continue to work with staff and patrons in the coming months to help them understand the new catalog and how it works.
- **Updating Desk Handbooks**
  - While training the new employee that was hired at the end of June, I noticed that some items in the handbooks for Library Clerks were out of date. I have been working on getting these updated so that staff has clear instructions on their regular duties and tasks.
  - I also got rid of the paper handbooks at each desk and have trained staff on accessing handbooks right on the desktop of their workstation.
  - This will save time and printing costs, as well as reduce clutter at the public desks.

- **Repairing and Replacing Books**

- This is an ongoing project. This summer I acquired another volunteer, so I currently have someone coming in on a weekly basis who glues books that have broken binding.
- One of the pages that has been working extra hours this summer is also helping with book gluing and disc cleaning.
- Both have been a huge help because, between the books and the media, I get about 50 things a week that need to be repaired. It has become nearly impossible to keep up on my own.
- I hope to find at least one more volunteer in the coming months to do disc cleaning and book gluing, as the page who is helping out will be going back to school in fall and will no longer be able to work extra hours.

## **Proposed Changes**

- **Food for Fines**

This past June we offered a Food for Fines that was incredibly successful. This program allowed people to get rid of any fines that might have prevented them from participating in the summer reading program. With the program we were able to waive over \$150 of fines.

I propose continuing this program and offering it again next June. We would be able to get people ready for summer reading and also give to the food pantry when they are most in need.

Thank you for letting me come speak with you today and for all you do for the library!

## PEWAUKEE PUBLIC LIBRARY BOARD MEETING

Wednesday, July 16, 2025 – 6:30 PM

1. Call Meeting to order and Roll Call: 6:30 PM  
 Members Present: Lisa Jansen, Leslie Miller, Dale Noll, Phil Vetterkind, Ann Wright, Karen Wildman, Rachel Pader  
 Others Present: Nan Champe (Library Director)

### SPECIAL BUSINESS

2. Introduction of new Board member – Rachel Pader

### REGULAR BUSINESS

3. Citizen Comments/Correspondence – n/a
4. Approval of Consent Agenda
  - a. Minutes June 18, 2025 (Regular Board Meeting)
  - b. Financial Reports
    - GL Budget vs. Actual Library – June 2025
    - GL Detail Library – June 2025
    - Payment Approval Report – June 2025
    - LGIP Statement – June 2025
  - d. Library Monthly Statistics Report through June 2025
  - e. Library Director's Report - July 2025

Motion to approve: Ann Wright  
 Second: Leslie Miller  
 Discussion: n/a  
 Motion carried Rachel Pader abstains

### OLD BUSINESS - none

### NEW BUSINESS

5. Discussion and possible action on the new Naming & Dedication Policy

Motion: Leslie Miller without any contingencies  
 Second: Karen Wildman  
 Discussion: n/a  
 Motion carried

6. Discussion and possible review of the Library’s current fund balance
  - Discussion: Include a copy of memo when submitting to Village & City for budget review
  - No action taken
  
7. Discussion and possible action on the 2026 Joint Library Budget
  - No action taken
  
8. Discussion and possible action on the Library’s 5 year capitol improvement plan
  - Discussion: Nan would like to pursue outdoor lockers. Cost approximately \$30,000. Would like fundraising. Would need to be attached to building. Connected to ILS system. Are there grants available?
  - No action taken
  
9. Discussion and possible action on *TE14: Library Board and Open Meetings Law*  
Discussion: Item #8 – review on taking the vote topic?
  - No action taken
  
10. ADJOURNMENT – 7:48 PM

Motion to approve: Phil Vetterkind  
Second: Karen Wildman  
Discussion: n/a  
Motion carried

NEXT MEETING: Wednesday August 20, 2025

End.GLPeriod 725

Account Number	Account Title	MTD	YTD	Budget	Variance	% Budget
<b>900 - LIBRARY FUND</b>						
900-00-11101-000-000	LIBRARY CASH(A)	72,330.03	75,406.23	.00	-75,406.23	100.00%
900-00-11109-000-000	LIBRARY GIFT ACCOUNT(A)	.00	.00	.00	.00	100.00%
900-00-12000-000-000	ACCOUNTS RECEIVABLE(A)	.00	.00	.00	.00	100.00%
900-00-12004-000-000	DUE FROM CITY OF PEWAUKEE(A)	.00	.00	.00	.00	100.00%
900-00-12004-000-100	DUE FROM GENERAL FUND(A)	.00	.00	.00	.00	100.00%
900-00-16552-000-000	LGIP #16 LIBRARY LGIP(A)	.00	101,423.17	.00	-101,423.17	100.00%
900-00-17100-000-000	PREPAID EXPENSES(A)	.00	.00	.00	.00	100.00%
900-00-11105-000-000	NORTH SHORE CD INVESTMENT(A)	.00	152,503.00	.00	-152,503.00	100.00%
900-00-11000-000-000	LIBRARY SWEEP(A)	4,880.87	61,964.08	.00	-61,964.08	100.00%
<b>Total Asset:</b>		<b>77,210.90</b>	<b>391,296.48</b>	<b>.00</b>	<b>-391,296.48</b>	
900-00-31101-000-000	FUND BALANCE(Q)	.00	-288,642.97	.00	288,642.97	100.00%
<b>Total Equity:</b>		<b>.00</b>	<b>-288,642.97</b>	<b>.00</b>	<b>288,642.97</b>	
900-00-55110-000-110	LIBRARY SALARIES & WAGES(E)	51,178.83	355,727.44	688,000.00	332,272.56	51.70%
900-00-55110-000-130	LIBRARY FRINGE BENEFITS(E)	16,228.52	127,210.83	223,435.00	96,224.17	56.93%
900-00-55110-000-140	LIBRARY-SUBSCRIPTIONS(E)	3,275.90	5,328.70	7,000.00	1,671.30	76.12%
900-00-55110-000-150	LIBRARY FISCAL AGENT/INS CHGS(E)	1,590.50	16,534.50	45,936.00	29,401.50	35.99%
900-00-55110-000-310	LIBRARY-BUILDING MAINTENANCE(E)	5,625.72	67,544.05	93,332.00	25,787.95	72.36%
900-00-55110-000-400	LEGAL COUNSEL-LIBRARY ATTORNEY(E)	1,380.00	3,072.50	4,000.00	927.50	76.81%
900-00-55110-000-500	DONATION FUNDED EXPENSE(E)	1,390.83	8,151.90	8,000.00	-151.90	101.89%
900-00-57610-000-000	LIBRARY OUTLAY(E)	112.00	7,356.26	25,000.00	17,643.74	29.42%
900-00-55110-000-141	LIBRARY-PRINTED MATERIALS(E)	4,771.82	30,663.11	80,500.00	49,836.89	38.09%
900-00-55110-000-142	LIBRARY-NON-PRINT MATERIALS(E)	815.21	7,729.22	14,700.00	6,970.78	52.57%
900-00-55110-000-143	LIBRARY-TECHNOLOGY(E)	1,460.25	34,472.37	45,548.00	11,075.63	75.68%
900-00-55110-000-144	LIBRARY-MILEAGE, SUPPLIES, ETC(E)	-984.46	4,428.99	14,045.00	9,616.01	31.53%

End.GLPeriod 725

Account Number	Account Title	MTD	YTD	Budget	Variance	% Budget
900-00-55110-000-146	LIBRARY-STAFF DEVELOPMENT(E)	.00	1,472.35	3,000.00	1,527.65	49.07%
900-00-55110-000-311	LIBRARY-UTILITIES(E)	5,214.53	26,244.67	52,930.00	26,685.33	49.58%
900-00-55110-000-312	LIBRARY-DIGITAL MATERIALS(E)	876.14	17,051.13	24,107.00	7,055.87	70.73%
900-00-55110-000-313	LIBRARY-PROGRAMS(E)	155.58	1,980.79	5,000.00	3,019.21	39.61%
900-00-55110-000-450	GRANT FUNDED EXPENSE(E)	1,402.50	13,246.72	7,263.00	-5,983.72	182.38%
900-00-55110-000-160	LIBRARY ANNUAL MUNICIPAL FEES(E)	.00	555.08	3,782.00	3,226.92	14.67%
<b>Total Expenditure:</b>		<b>94,493.87</b>	<b>728,770.61</b>	<b>1,345,578.00</b>	<b>616,807.39</b>	
900-00-21400-000-000	VOUCHERS PAYABLE(L)	.00	.19	.00	-.19	100.00%
900-00-21400-000-100	FLEX BENEFITS PAYABLE(L)	.00	.00	.00	.00	100.00%
900-00-21401-000-000	DEFERRED REVENUE(L)	.00	.00	.00	.00	100.00%
900-00-21402-000-000	ACCRUED PAYROLL(L)	.00	.00	.00	.00	100.00%
900-00-21500-000-000	WISCONSIN SALES TAX(L)	.00	.00	.00	.00	100.00%
900-00-21720-000-000	DUE TO OTHER FUNDS(L)	.00	.00	.00	.00	100.00%
900-00-23503-000-000	DEPOSITS - CITY CONTRIBUTIONS(L)	.00	.00	.00	.00	100.00%
900-00-23504-000-000	DEPOSITS - DES GRNTS/DONATIONS(L)	.00	.00	.00	.00	100.00%
<b>Total Liability:</b>		<b>.00</b>	<b>.19</b>	<b>.00</b>	<b>-.19</b>	
900-00-43790-000-000	COUNTY LIBRARY AIDS(R)	.00	-59,382.50	-114,563.00	-55,180.50	51.83%
900-00-46710-000-000	LIBRARY FINES(R)	-1,219.07	-5,465.21	-8,681.00	-3,215.79	62.95%
900-00-48110-000-000	INTEREST INCOME(R)	.00	-3,393.73	-9,769.00	-6,375.27	34.73%
900-00-48200-000-100	FISCAL AGENT FEES(R)	.00	.00	.00	.00	100.00%
900-00-48500-000-000	DONATIONS, PRIVATE OR ORGANIZ(R)	-2,012.90	-19,713.29	-8,000.00	11,713.29	246.41%
900-00-48500-000-100	MISC REVENUES(R)	-503.00	-4,603.76	-8,251.00	-3,647.24	55.79%
900-00-48500-000-200	DESIGNATED GRANTS(R)	-450.00	-4,013.00	-7,263.00	-3,250.00	55.25%
900-00-49000-000-000	CITY CONTRIBUTION PAYMENTS(R)	-144,977.82	-579,911.36	-869,687.00	-289,775.64	66.68%
900-00-49001-000-000	VILLAGE CONTRIBUTION PAYMENTS(R)	-21,846.08	-152,922.56	-262,153.00	-109,230.44	58.33%

End.GLPeriod 725

Account Number	Account Title	MTD	YTD	Budget	Variance	% Budget
900-00-49200-000-000	TRANSFER IN FROM MUNICIPALITY(R)	.00	.00	.00	.00	100.00%
900-00-49300-000-000	FUND BALANCE APPLIED(R)	.00	.00	-57,211.00	-57,211.00	0.00%
900-00-48440-000-000	INSURANCE RECOVERIES(R)	.00	.00	.00	.00	100.00%
900-00-48500-000-300	COPIES & ROOM RENTAL(R)	-695.90	-2,018.90	.00	2,018.90	100.00%
<b>Total Revenue:</b>		<b>-171,704.77</b>	<b>-831,424.31</b>	<b>-1,345,578.00</b>	<b>-514,153.69</b>	
<b>Total 900 - LIBRARY FUND:</b>		<b>.00</b>	<b>.00</b>	<b>.00</b>	<b>.00</b>	
<b>Total:</b>		<b>.00</b>	<b>.00</b>	<b>.00</b>	<b>.00</b>	

End.GLPeriod 825 AND Start.GLPeriod 825

Date	Ref#	Journal	Description	Activity	Job	Debit	Credit
Fund900 - LIBRARY FUND							
Account Number And Title900-00-11101-000-000 - LIBRARY CASH							
08/01/2025	9-1	CA-CDA	CDA Fund Allocation - Created: 07/31/25 1:51 PM			.00	-14,061.74
08/31/2025	2-1	CA-JE	JE Fund Allocation - Created: 08/01/25 8:45 AM			20,255.58	.00
08/31/2025	6-1	CA-PB	PB Fund Allocation - Created: 07/30/25 11:01 AM			.00	-3,202.10
08/31/2025	6-1	CA-PC	PC Fund Allocation - Created: 07/30/25 11:01 AM			.00	-25,655.19
<b>Account Number And Title900-00-11101-000-000 - LIBRARY CASH</b>						<b>20,255.58</b>	<b>-42,919.03</b>
Account Number And Title900-00-21400-000-000 - VOUCHERS PAYABLE							
08/01/2025	75294-1	CDA	AMAZON CAPITAL SERVICES, INC.			140.38	.00
08/01/2025	75305-1	CDA	INGRAM LIBRARY SERVICES LLC			282.08	.00
08/01/2025	75306-1	CDA	J & H HEATING INC			2,275.00	.00
08/01/2025	75309-1	CDA	MCNAMARA MCCARTHY SCHOOL OF IRISH DANCE			100.00	.00
08/01/2025	75310-1	CDA	MIDWEST TAPE			167.91	.00
08/01/2025	75311-1	CDA	MILWAUKEE PLUMBING & PIPING INC			428.80	.00
08/01/2025	75314-6	CDA	PEWAUKEE UTILITY			585.65	.00
08/04/2025	300000631-1	CDA	ACH NORTH SHORE BANK CREDIT CARD			10,081.92	.00
08/31/2025	42-1	AP	Summary Transactions from AP System			.00	-10,081.92
08/31/2025	125-1	AP	Summary Transactions from AP System			.00	-3,979.82
<b>Account Number And Title900-00-21400-000-000 - VOUCHERS PAYABLE</b>						<b>14,061.74</b>	<b>-14,061.74</b>
Account Number And Title900-00-49001-000-000 - VILLAGE CONTRIBUTION PAYMENTS							
08/01/2025	1-2	JE	LIBRARY CONTRIBUTION AUGUST			.00	-21,846.08
<b>Account Number And Title900-00-49001-000-000 - VILLAGE CONTRIBUTION PAYMENTS</b>						<b>.00</b>	<b>-21,846.08</b>
Account Number And Title900-00-55110-000-110 - LIBRARY SALARIES & WAGES							
08/01/2025	13-1	PC	PAYROLL TRANS FOR 7/27/2025 PAY PERIOD			25,655.19	.00

End.GLPeriod 825 AND Start.GLPeriod 825

Date	Ref#	Journal	Description	Activity	Job	Debit	Credit
<b>Account Number And Title 900-00-55110-000-110 - LIBRARY SALARIES &amp; WAGES</b>						<b>25,655.19</b>	<b>.00</b>
Account Number And Title 900-00-55110-000-130 - LIBRARY FRINGE BENEFITS							
08/01/2025	4-1	PB	PAYROLL TRANS FOR 7/27/2025 PAY PERIOD			3,202.10	.00
<b>Account Number And Title 900-00-55110-000-130 - LIBRARY FRINGE BENEFITS</b>						<b>3,202.10</b>	<b>.00</b>
Account Number And Title 900-00-55110-000-140 - LIBRARY-SUBSCRIPTIONS							
07/05/2025	4-1	AP	ACH NORTH SHORE BANK CREDIT CARD			194.97	.00
<b>Account Number And Title 900-00-55110-000-140 - LIBRARY-SUBSCRIPTIONS</b>						<b>194.97</b>	<b>.00</b>
Account Number And Title 900-00-55110-000-141 - LIBRARY-PRINTED MATERIALS							
05/30/2025	9-1	AP	ACH NORTH SHORE BANK CREDIT CARD			55.34	.00
06/02/2025	12-1	AP	ACH NORTH SHORE BANK CREDIT CARD			56.61	.00
06/03/2025	10-1	AP	ACH NORTH SHORE BANK CREDIT CARD			353.45	.00
06/03/2025	11-1	AP	ACH NORTH SHORE BANK CREDIT CARD			258.17	.00
06/05/2025	13-1	AP	ACH NORTH SHORE BANK CREDIT CARD			247.30	.00
06/06/2025	14-1	AP	ACH NORTH SHORE BANK CREDIT CARD			343.61	.00
06/06/2025	15-1	AP	ACH NORTH SHORE BANK CREDIT CARD			33.69	.00
06/09/2025	17-1	AP	ACH NORTH SHORE BANK CREDIT CARD			26.52	.00
06/10/2025	18-1	AP	ACH NORTH SHORE BANK CREDIT CARD			230.90	.00
06/10/2025	16-1	AP	ACH NORTH SHORE BANK CREDIT CARD			358.25	.00
06/11/2025	19-1	AP	ACH NORTH SHORE BANK CREDIT CARD			163.82	.00
06/11/2025	20-1	AP	ACH NORTH SHORE BANK CREDIT CARD			305.49	.00
06/16/2025	21-1	AP	ACH NORTH SHORE BANK CREDIT CARD			86.72	.00
06/16/2025	23-1	AP	ACH NORTH SHORE BANK CREDIT CARD			48.26	.00
06/17/2025	22-1	AP	ACH NORTH SHORE BANK CREDIT CARD			86.16	.00
06/18/2025	24-1	AP	ACH NORTH SHORE BANK CREDIT CARD			532.93	.00

End.GLPeriod 825 AND Start.GLPeriod 825

Date	Ref#	Journal	Description	Activity	Job	Debit	Credit
06/19/2025	25-1	AP	ACH NORTH SHORE BANK CREDIT CARD			26.52	.00
06/20/2025	26-1	AP	ACH NORTH SHORE BANK CREDIT CARD			167.88	.00
06/20/2025	27-1	AP	ACH NORTH SHORE BANK CREDIT CARD			304.29	.00
06/26/2025	28-1	AP	ACH NORTH SHORE BANK CREDIT CARD			73.23	.00
06/30/2025	29-1	AP	ACH NORTH SHORE BANK CREDIT CARD			242.42	.00
06/30/2025	31-1	AP	ACH NORTH SHORE BANK CREDIT CARD			255.44	.00
06/30/2025	32-1	AP	ACH NORTH SHORE BANK CREDIT CARD			20.54	.00
07/01/2025	33-1	AP	ACH NORTH SHORE BANK CREDIT CARD			122.69	.00
07/01/2025	34-1	AP	ACH NORTH SHORE BANK CREDIT CARD			196.56	.00
07/01/2025	35-1	AP	ACH NORTH SHORE BANK CREDIT CARD			146.10	.00
07/01/2025	30-1	AP	ACH NORTH SHORE BANK CREDIT CARD			187.92	.00
07/14/2025	72-1	AP	AMAZON CAPITAL SERVICES, INC.			9.74	.00
07/15/2025	68-1	AP	INGRAM LIBRARY SERVICES LLC			282.08	.00
<b>Account Number And Title900-00-55110-000-141 - LIBRARY-PRINTED MATERIALS</b>						<b>5,222.63</b>	<b>.00</b>
Account Number And Title900-00-55110-000-142 - LIBRARY-NON-PRINT MATERIALS							
07/14/2025	88-1	AP	MIDWEST TAPE			110.19	.00
07/14/2025	89-1	AP	MIDWEST TAPE			37.48	.00
07/14/2025	90-1	AP	MIDWEST TAPE			20.24	.00
07/15/2025	74-1	AP	AMAZON CAPITAL SERVICES, INC.			84.94	.00
<b>Account Number And Title900-00-55110-000-142 - LIBRARY-NON-PRINT MATERIALS</b>						<b>252.85</b>	<b>.00</b>
Account Number And Title900-00-55110-000-143 - LIBRARY-TECHNOLOGY							
06/16/2025	39-1	AP	ACH NORTH SHORE BANK CREDIT CARD			765.00	.00
06/30/2025	37-1	AP	ACH NORTH SHORE BANK CREDIT CARD			6.00	.00
<b>Account Number And Title900-00-55110-000-143 - LIBRARY-TECHNOLOGY</b>						<b>771.00</b>	<b>.00</b>

VILLAGE OF PEWAUKEE

## GL Detail

August 07, 2025 09:59 AM

End.GLPeriod 825 AND Start.GLPeriod 825

Date	Ref#	Journal	Description	Activity	Job	Debit	Credit
Account Number And Title900-00-55110-000-144 - LIBRARY-MILEAGE, SUPPLIES, ETC							
06/10/2025	5-1	AP	ACH NORTH SHORE BANK CREDIT CARD			139.42	.00
06/16/2025	40-1	AP	ACH NORTH SHORE BANK CREDIT CARD			2,131.02	.00
06/21/2025	2-1	AP	ACH NORTH SHORE BANK CREDIT CARD			27.47	.00
07/01/2025	38-1	AP	ACH NORTH SHORE BANK CREDIT CARD			748.76	.00
<b>Account Number And Title900-00-55110-000-144 - LIBRARY-MILEAGE, SUPPLIES, ETC</b>						<b>3,046.67</b>	<b>.00</b>
Account Number And Title900-00-55110-000-150 - LIBRARY FISCAL AGENT/INS CHGS							
08/01/2025	2-1	JE	LIBRARY FISCAL AGENT FEE AUGUST			1,590.50	.00
<b>Account Number And Title900-00-55110-000-150 - LIBRARY FISCAL AGENT/INS CHGS</b>						<b>1,590.50</b>	<b>.00</b>
Account Number And Title900-00-55110-000-160 - LIBRARY ANNUAL MUNICIPAL FEES							
07/10/2025	52-1	AP	PEWAUKEE UTILITY			585.65	.00
<b>Account Number And Title900-00-55110-000-160 - LIBRARY ANNUAL MUNICIPAL FEES</b>						<b>585.65</b>	<b>.00</b>
Account Number And Title900-00-55110-000-310 - LIBRARY-BUILDING MAINTENANCE							
07/13/2025	87-1	AP	MILWAUKEE PLUMBING & PIPING INC			428.80	.00
07/15/2025	75-1	AP	J & H HEATING INC			2,275.00	.00
<b>Account Number And Title900-00-55110-000-310 - LIBRARY-BUILDING MAINTENANCE</b>						<b>2,703.80</b>	<b>.00</b>
Account Number And Title900-00-55110-000-311 - LIBRARY-UTILITIES							
01/16/2025	7-1	AP	ACH NORTH SHORE BANK CREDIT CARD			372.34	.00
04/16/2025	36-1	AP	ACH NORTH SHORE BANK CREDIT CARD			.65	.00
07/14/2025	6-1	AP	ACH NORTH SHORE BANK CREDIT CARD			234.99	.00
<b>Account Number And Title900-00-55110-000-311 - LIBRARY-UTILITIES</b>						<b>607.98</b>	<b>.00</b>
Account Number And Title900-00-55110-000-500 - DONATION FUNDED EXPENSE							
06/12/2025	8-1	AP	ACH NORTH SHORE BANK CREDIT CARD			450.00	.00
06/18/2025	1-1	AP	ACH NORTH SHORE BANK CREDIT CARD			10.00	.00

VILLAGE OF PEWAUKEE

## GL Detail

August 07, 2025 09:59 AM

End.GLPeriod 825 AND Start.GLPeriod 825

Date	Ref#	Journal	Description	Activity	Job	Debit	Credit
07/01/2025	3-1	AP	ACH NORTH SHORE BANK CREDIT CARD			70.49	.00
07/15/2025	67-1	AP	MCNAMARA MCCARTHY SCHOOL OF IRISH DANCE			100.00	.00
07/17/2025	73-1	AP	AMAZON CAPITAL SERVICES, INC.			45.70	.00
<b>Account Number And Title 900-00-55110-000-500 - DONATION FUNDED EXPENSE</b>						<b>676.19</b>	<b>.00</b>
<b>Total:</b>						<b>78,826.85</b>	<b>-78,826.85</b>

APIInvoiceApprovalDepartment.DepartmentName LIBRARY AND GeneralLedgerPeriod.GLPeriod 725

Vendor	Vendor Name	Invoice Number	Description	Invoice Amount	Invoice Date	Due Date	Batch	GL Period	Status
<b>ACH NORTH SHORE BANK CREDIT CARD</b>									
<b>Approved</b>									
13040	ACH NORTH SHORE BANK CREDIT CARD	3444ADJ	LIBRARY/C YBERLYNK JUNE 2025	0.65	04/16/2025	08/04/2025			Approved
13040	ACH NORTH SHORE BANK CREDIT CARD	06212025	LIBRARY/C OPY PAPER	27.47	06/21/2025	08/04/2025			Approved
13040	ACH NORTH SHORE BANK CREDIT CARD	07052025	LIBRARY/W SJ/3RD QUARTER SUBSCRIPTI ON PAYMENT	194.97	07/05/2025	08/04/2025			Approved
13040	ACH NORTH SHORE BANK CREDIT CARD	1645	LIBRARY/C YBERLYNK JAN 2025	372.34	01/16/2025	08/04/2025			Approved
13040	ACH NORTH SHORE BANK CREDIT CARD	7664810	LIBRARY/P ROCESSING SUPPLIES	748.76	07/01/2025	08/04/2025			Approved
13040	ACH NORTH SHORE BANK CREDIT CARD	1499095	LIBRARY/P ROCESSING MATERIALS	139.42	06/10/2025	08/04/2025			Approved
13040	ACH NORTH SHORE BANK CREDIT CARD	5289268125	LIBRARY/G OOGLE GSUITE JUNE 2025	6.00	06/30/2025	08/04/2025			Approved
13040	ACH NORTH SHORE BANK CREDIT CARD	152358301071425	LIBRARY/S PECTRUM 7.17.25- 8.16.25	234.99	07/14/2025	08/04/2025			Approved
13040	ACH NORTH SHORE BANK CREDIT CARD	CE4EF2C2-0008	LIBRARY/S LING	765.00	06/16/2025	08/04/2025			Approved
13040	ACH NORTH SHORE BANK CREDIT CARD	ORD11692418	LIBRARY/B OOK CARTS	2131.02	06/16/2025	08/04/2025			Approved
13040	ACH NORTH SHORE BANK CREDIT CARD	2039164755	LIBRARY/Y A BOOKS	146.10	07/01/2025	08/04/2025			Approved
13040	ACH NORTH SHORE BANK CREDIT CARD	2039164751	LIBRARY/J UV PICTURE B	196.56	07/01/2025	08/04/2025			Approved

APIInvoiceApprovalDepartment.DepartmentName LIBRARY AND GeneralLedgerPeriod.GLPeriod 725

Vendor	Vendor Name	Invoice Number	Description	Invoice Amount	Invoice Date	Due Date	Batch	GL Period	Status
13040	ACH NORTH SHORE BANK CREDIT CARD	2039163342	LIBRARY/A DULT NONFIC	187.92	07/01/2025	08/04/2025			Approved
13040	ACH NORTH SHORE BANK CREDIT CARD	2039164737	LIBRARY/Y A BOOKS	122.69	07/01/2025	08/04/2025			Approved
13040	ACH NORTH SHORE BANK CREDIT CARD	2039163581	LIBRARY/J UV BOOKS	20.54	06/30/2025	08/04/2025			Approved
13040	ACH NORTH SHORE BANK CREDIT CARD	2039158575	LIBRARY/Y A BOOKS	73.23	06/26/2025	08/04/2025			Approved
13040	ACH NORTH SHORE BANK CREDIT CARD	2039160336	LIBRARY/A DULT FIC	242.42	06/30/2025	08/04/2025			Approved
13040	ACH NORTH SHORE BANK CREDIT CARD	2039147947	LIBRARY/J UV BOOKS	26.52	06/19/2025	08/04/2025			Approved
13040	ACH NORTH SHORE BANK CREDIT CARD	2039163366	LIBRARY/J UV PICTURE B	255.44	06/30/2025	08/04/2025			Approved
13040	ACH NORTH SHORE BANK CREDIT CARD	2039142685	LIBRARY/A DULT FIC	532.93	06/18/2025	08/04/2025			Approved
13040	ACH NORTH SHORE BANK CREDIT CARD	2039148385	LIBRARY/J UV PICTURE B	167.88	06/20/2025	08/04/2025			Approved
13040	ACH NORTH SHORE BANK CREDIT CARD	2039141812	LIBRARY/A DULT SCIFI	48.26	06/16/2025	08/04/2025			Approved
13040	ACH NORTH SHORE BANK CREDIT CARD	2039140511	LIBRARY/J UV PICTURE B	86.72	06/16/2025	08/04/2025			Approved
13040	ACH NORTH SHORE BANK CREDIT CARD	2039141308	LIBRARY/Y A BOOKS	86.16	06/17/2025	08/04/2025			Approved
13040	ACH NORTH SHORE BANK CREDIT CARD	2039148619	LIBRARY/A DULT NONFIC	304.29	06/20/2025	08/04/2025			Approved
13040	ACH NORTH SHORE BANK CREDIT CARD	2039133635	LIBRARY/A DULT NONFIC	163.82	06/11/2025	08/04/2025			Approved
13040	ACH NORTH SHORE BANK CREDIT CARD	2039130904	LIBRARY/A DULT FIC	230.90	06/10/2025	08/04/2025			Approved
13040	ACH NORTH SHORE BANK CREDIT CARD	2039126796	LIBRARY/A DULT FIC	358.25	06/10/2025	08/04/2025			Approved
13040	ACH NORTH SHORE BANK CREDIT CARD	2039122771	LIBRARY/A DULT SCIFI	33.69	06/06/2025	08/04/2025			Approved

APIInvoiceApprovalDepartment.DepartmentName LIBRARY AND GeneralLedgerPeriod.GLPeriod 725

Vendor	Vendor Name	Invoice Number	Description	Invoice Amount	Invoice Date	Due Date	Batch	GL Period	Status
13040	ACH NORTH SHORE BANK CREDIT CARD	2039133758	LIBRARY/J UV PICTURE B	305.49	06/11/2025	08/04/2025			Approved
13040	ACH NORTH SHORE BANK CREDIT CARD	2039112371	LIBRARY/A DULT FIC	258.17	06/03/2025	08/04/2025			Approved
13040	ACH NORTH SHORE BANK CREDIT CARD	2039120832	LIBRARY/Y A BOOKS	343.61	06/06/2025	08/04/2025			Approved
13040	ACH NORTH SHORE BANK CREDIT CARD	2039108472	LIBRARY/J UV PICTURE B	55.34	05/30/2025	08/04/2025			Approved
13040	ACH NORTH SHORE BANK CREDIT CARD	2039112557	LIBRARY/Y A BOOKS	56.61	06/02/2025	08/04/2025			Approved
13040	ACH NORTH SHORE BANK CREDIT CARD	2039111004	LIBRARY/A DULT NONFIC	353.45	06/03/2025	08/04/2025			Approved
13040	ACH NORTH SHORE BANK CREDIT CARD	2039118905	LIBRARY/J UV PICTURE B	247.30	06/05/2025	08/04/2025			Approved
13040	ACH NORTH SHORE BANK CREDIT CARD	2039127388	LIBRARY/J UV BOOKS	26.52	06/09/2025	08/04/2025			Approved
13040	ACH NORTH SHORE BANK CREDIT CARD	2004	LIBRARY/F RIENDS SUMMER KICKOFF INFLATABL E	450.00	06/12/2025	08/04/2025			Approved
13040	ACH NORTH SHORE BANK CREDIT CARD	07012025	LIBRARY/KI WANIS/YA PROGRAM	70.49	07/01/2025	08/04/2025			Approved
13040	ACH NORTH SHORE BANK CREDIT CARD	0621 03746 02 587 26299279	LIBRARY/KI WANIS/YA PROGRAM TREATS	10.00	06/18/2025	08/04/2025			Approved
13040	ACH NORTH SHORE BANK CREDIT CARD	ORD11692418-CR	LIBRARY/S CHOO L OUTFITTER S REFUND	-1464.10	06/27/2025	07/04/2025			Approved

**Total ACH NORTH SHORE BANK CREDIT CARD:** 8617.82

**ACH WE ENERGIES**

APIInvoiceApprovalDepartment.DepartmentName LIBRARY AND GeneralLedgerPeriod.GLPeriod 725

Vendor	Vendor Name	Invoice Number	Description	Invoice Amount	Invoice Date	Due Date	Batch	GL Period	Status
<b>Approved</b>									
13090	ACH WE ENERGIES	5542775667	LIBRARY/21 0 MAIN ST	4606.55	07/09/2025	07/31/2025			Approved
<b>Total ACH WE ENERGIES:</b>				<u>4606.55</u>					
<b>AMAZON CAPITAL SERVICES, INC.</b>									
<b>Approved</b>									
23	AMAZON CAPITAL SERVICES, INC.	1RJ4-4FTD-FC4R	LIBRARY/ ADULT CDS 3	36.35	07/19/2025	08/18/2025			Approved
23	AMAZON CAPITAL SERVICES, INC.	1WHM-TP4X-YJ1X	LIBRARY/C LEANING SUPPLIES	247.54	07/19/2025	08/18/2025			Approved
23	AMAZON CAPITAL SERVICES, INC.	1WHM-TP4X- YCPR	LIBRARY/Y A FIC	12.78	07/19/2025	08/18/2025			Approved
23	AMAZON CAPITAL SERVICES, INC.	1RDN-NXFN-GN17	LIBRARY/F RIENDS/LIB RARY OF THINGS	441.35	07/19/2025	08/18/2025			Approved
23	AMAZON CAPITAL SERVICES, INC.	1G3Y-7DF7-M7HX	LIBRARY/J UV PROGRAM	186.61	07/17/2025	08/18/2025			Approved
23	AMAZON CAPITAL SERVICES, INC.	1WHM-LFJY- WDN1	LIBRARY/A DULT DVDS 3	84.94	07/15/2025	08/14/2025			Approved
23	AMAZON CAPITAL SERVICES, INC.	1V6G-733R-RHYH	LIBRARY/F RIENDS/LIB RARY OF THINGS	97.61	07/11/2025	08/08/2025			Approved
23	AMAZON CAPITAL SERVICES, INC.	1QL1-NN7L-LMMJ	LIBRARY/F RIENDS/LIB RARY OF THINGS	45.70	07/17/2025	08/14/2025			Approved
23	AMAZON CAPITAL SERVICES, INC.	1GJ4-D7XH-4C9R	LIBRARY/J UV FIC	9.74	07/14/2025	08/14/2025			Approved
23	AMAZON CAPITAL SERVICES, INC.	114N-1NJM-GDFG	LIBRARY/A DULT FIC	28.00	07/09/2025	08/08/2025			Approved
23	AMAZON CAPITAL SERVICES, INC.	14WH-QGXR- 7WTH	LIBRARY/F RIENDS/LIB	58.96	07/10/2025	08/08/2025			Approved

APIInvoiceApprovalDepartment.DepartmentName LIBRARY AND GeneralLedgerPeriod.GLPeriod 725

Vendor	Vendor Name	Invoice Number	Description	Invoice Amount	Invoice Date	Due Date	Batch	GL Period	Status
23	AMAZON CAPITAL SERVICES, INC.	114N-1NJM-1GR7	RARY OF THINGS LIBRARY/A DULT FIC	40.17	07/08/2025	08/08/2025			Approved
23	AMAZON CAPITAL SERVICES, INC.	1M31-9LFX-1WH4	LIBRARY/ ADULT DVDS	78.75	07/01/2025	07/28/2025			Approved
23	AMAZON CAPITAL SERVICES, INC.	1LC7-4XGY-H7LW	LIBRARY/ ADULT CD	12.99	06/30/2025	07/28/2025			Approved
23	AMAZON CAPITAL SERVICES, INC.	193C-XMHY-194V	LIBRARY/J UV FIC	134.27	06/29/2025	07/28/2025			Approved
23	AMAZON CAPITAL SERVICES, INC.	1713-PCMN-P63R	LIBRARY/A DULT FIC	30.64	06/28/2025	07/28/2025			Approved
23	AMAZON CAPITAL SERVICES, INC.	1Q3F-NDJ1-L3CQ	LIBRARY/J UV MUSIC	59.94	07/03/2025	07/30/2025			Approved
23	AMAZON CAPITAL SERVICES, INC.	19G4-1LXQ-17D4	INSTRUMENTS KIWANIS LIBRARY/C OPY PAPER	119.31	06/29/2025	07/30/2025			Approved
23	AMAZON CAPITAL SERVICES, INC.	1HKP-PH1C-GFPG	LIBRARY/J UV PROGRAM KIWANIS	85.98	06/30/2025	07/30/2025			Approved
<b>Total AMAZON CAPITAL SERVICES, INC.:</b>				<b>1811.63</b>					
<b>BATZNER PEST CONTROL INC</b>									
<b>Approved</b>									
7070	BATZNER PEST CONTROL INC	80104019	LIBRARY/P EST MGMT JULY 2025	120.56	07/02/2025	08/01/2025			Approved
<b>Total BATZNER PEST CONTROL INC:</b>				<b>120.56</b>					
<b>CENTER POINT LARGE PRINT</b>									
<b>Approved</b>									
3552	CENTER POINT LARGE PRINT	2179461	LIBRARY/L G PRINT BOOKS (2)	51.54	07/01/2025	08/01/2025			Approved

APIInvoiceApprovalDepartment.DepartmentName LIBRARY AND GeneralLedgerPeriod.GLPeriod 725

Vendor	Vendor Name	Invoice Number	Description	Invoice Amount	Invoice Date	Due Date	Batch	GL Period	Status
<b>Total CENTER POINT LARGE PRINT:</b>				<u>51.54</u>					
<b>CHAMPE, ELIZABETH</b>									
<b>Approved</b>									
11012	CHAMPE, ELIZABETH	20250718CHAMPE	LIBRARY/F RIENDS SUMMER KICKOFF	69.93	07/18/2025	07/18/2025			Approved
<b>Total CHAMPE, ELIZABETH:</b>				<u>69.93</u>					
<b>CULLIGAN</b>									
<b>Approved</b>									
13358	CULLIGAN	501X18037402	LIBRARY/P ERMIT FEE CULLIGAN	112.00	06/30/2025	07/30/2025			Approved
<b>Total CULLIGAN:</b>				<u>112.00</u>					
<b>EBSCO PAYMENT PROCESSING CENTER</b>									
<b>Approved</b>									
245	EBSCO PAYMENT PROCESSING CENTER	1760850	LIBRARY/M AGAZINE SUBSCRIPTI ON RENEWALS	3275.90	07/02/2025	08/02/2025			Approved
<b>Total EBSCO PAYMENT PROCESSING CENTER:</b>				<u>3275.90</u>					
<b>INGRAM LIBRARY SERVICES LLC</b>									
<b>Approved</b>									
13350	INGRAM LIBRARY SERVICES LLC	89375039	LIBRARY/IN GRAM BOOKS	288.91	07/24/2025	08/24/2025			Approved
13350	INGRAM LIBRARY SERVICES LLC	89196394	LIBRARY/IN GRAM BOOKS	282.08	07/15/2025	07/16/2025			Approved
13350	INGRAM LIBRARY SERVICES LLC	89218567	LIBRARY/J UV NONFIC	560.35	07/16/2025	08/16/2025			Approved

APIInvoiceApprovalDepartment.DepartmentName LIBRARY AND GeneralLedgerPeriod.GLPeriod 725

Vendor	Vendor Name	Invoice Number	Description	Invoice Amount	Invoice Date	Due Date	Batch	GL Period	Status
13350	INGRAM LIBRARY SERVICES LLC	88993933	LIBRARY/A DULT FIC	322.84	07/03/2025	08/03/2025			Approved
13350	INGRAM LIBRARY SERVICES LLC	88850716	LIBRARY/A DULT FIC	326.02	06/25/2025	07/25/2025			Approved
<b>Total INGRAM LIBRARY SERVICES LLC:</b>				<u><b>1780.20</b></u>					
<b>IRVIN L. YOUNG MEMORIAL LIBRARY</b>									
<b>Approved</b>									
13356	IRVIN L. YOUNG MEMORIAL LIBRARY	20250603YEL	LIBRARY/R EIMBURSE MENT REPLACEM ENT/ITEM 33488002777 991	22.00	07/24/2025	08/24/2025			Approved
<b>Total IRVIN L. YOUNG MEMORIAL LIBRARY:</b>				<u><b>22.00</b></u>					
<b>J &amp; H HEATING INC</b>									
<b>Approved</b>									
2984	J & H HEATING INC	W38560	LIBRARY/H VAC 2025 SPRING PREVENTA TIVE MAINTENA NCE	2275.00	07/15/2025	08/15/2025			Approved
<b>Total J &amp; H HEATING INC:</b>				<u><b>2275.00</b></u>					
<b>JANI-KING OF MILWAUKEE</b>									
<b>Approved</b>									
12411	JANI-KING OF MILWAUKEE	MIL08250350	LIBRARY/J ANITORIAL SVC AUGUST 2025	2784.02	08/01/2025	09/01/2025			Approved
<b>Total JANI-KING OF MILWAUKEE:</b>				<u><b>2784.02</b></u>					
<b>JF AHERN COMPANY</b>									

APIInvoiceApprovalDepartment.DepartmentName LIBRARY AND GeneralLedgerPeriod.GLPeriod 725

Vendor	Vendor Name	Invoice Number	Description	Invoice Amount	Invoice Date	Due Date	Batch	GL Period	Status
<b>Approved</b>									
4875	JF AHERN COMPANY	748115	LIBRARY/FIRE SPRINKLER INSP - QUARTERLY JULY 2025	188.00	07/18/2025	08/18/2025			Approved
<b>Total JF AHERN COMPANY:</b>				<u>188.00</u>					
<b>KUJAWA ENTERPRISES INC</b>									
<b>Approved</b>									
6819	KUJAWA ENTERPRISES INC	490885	LIBRARY/LANDSCAPE MNT - JULY 2025	2313.25	07/01/2025	08/01/2025			Approved
<b>Total KUJAWA ENTERPRISES INC:</b>				<u>2313.25</u>					
<b>MADISON COOPER</b>									
<b>Approved</b>									
13259	MADISON COOPER	20250606	COOPER LIBRARY/FRIENDS/MEMORYCAFE	37.45	07/18/2025	07/18/2025			Approved
13259	MADISON COOPER	20250708	COOPER LIBRARY/FRIENDS/ADULTPROGRAMPRIZES	22.50	07/18/2025	07/18/2025			Approved
<b>Total MADISON COOPER:</b>				<u>59.95</u>					
<b>MCNAMARA MCCARTHY SCHOOL OF IRISH DANCE</b>									
<b>Approved</b>									
13269	MCNAMARA MCCARTHY SCHOOL OF IRISH DANCE	1009	LIBRARY/JUVENILE PERFORMANCE KIWANIS	100.00	07/15/2025	08/14/2025			Approved
<b>Total MCNAMARA MCCARTHY SCHOOL OF IRISH DANCE:</b>				<u>100.00</u>					

APIInvoiceApprovalDepartment.DepartmentName LIBRARY AND GeneralLedgerPeriod.GLPeriod 725

Vendor	Vendor Name	Invoice Number	Description	Invoice Amount	Invoice Date	Due Date	Batch	GL Period	Status
<b>MIDWEST TAPE</b>									
<b>Approved</b>									
548	MIDWEST TAPE	507486185	LIBRARY/1 ADULT DVD	26.99	07/21/2025	08/21/2025			Approved
548	MIDWEST TAPE	507486184	LIBRARY/1 ADULT DVD	14.99	07/21/2025	08/21/2025			Approved
548	MIDWEST TAPE	507486182	LIBRARY/1 ADULT DVD	54.74	07/21/2025	08/21/2025			Approved
548	MIDWEST TAPE	507452895	LIBRARY/6 ADULT DVD	110.19	07/14/2025	08/14/2025			Approved
548	MIDWEST TAPE	507452896	LIBRARY/2 ADULT DVD	37.48	07/14/2025	08/14/2025			Approved
548	MIDWEST TAPE	507452898	LIBRARY/1 ADULT DVD	20.24	07/14/2025	08/14/2025			Approved
548	MIDWEST TAPE	507405834	LIBRARY/1 ADULT DVD	54.74	07/03/2025	08/03/2025			Approved
548	MIDWEST TAPE	507383182	LIBRARY/2 ADULT CD	23.98	06/27/2025	07/27/2025			Approved
548	MIDWEST TAPE	507383184	LIBRARY/3 ADULT DVD	78.72	06/27/2025	07/27/2025			Approved
548	MIDWEST TAPE	507383185	LIBRARY/3 ADULT DVD	87.72	06/27/2025	07/27/2025			Approved
<b>Total MIDWEST TAPE:</b>				<b>509.79</b>					
<b>MIDWEST TAPE - HOOPLA</b>									
<b>Approved</b>									
12821	MIDWEST TAPE - HOOPLA	507398279	LIBRARY/H OOPLA INSTANT JUNE 2025	876.14	06/30/2025	07/30/2025			Approved
<b>Total MIDWEST TAPE - HOOPLA:</b>				<b>876.14</b>					
<b>MILWAUKEE PLUMBING &amp; PIPING INC</b>									
<b>Approved</b>									
5391	MILWAUKEE PLUMBING & PIPING INC	53353	LIBRARY/P LUMBING REPAIRS	428.80	07/13/2025	08/13/2025			Approved

APIInvoiceApprovalDepartment.DepartmentName LIBRARY AND GeneralLedgerPeriod.GLPeriod 725

Vendor	Vendor Name	Invoice Number	Description	Invoice Amount	Invoice Date	Due Date	Batch	GL Period	Status
			URINAL						
<b>Total MILWAUKEE PLUMBING &amp; PIPING INC:</b>				<b>428.80</b>					
<b>OCONOMOWOC PUBLIC LIBRARY</b>									
<b>Approved</b>									
13361	OCONOMOWOC PUBLIC LIBRARY	30567003521913	LIBRARY/R EPLACEME NT CHARGE REIMBURSE MENT	9.00	07/29/2025	08/29/2025			Approved
<b>Total OCONOMOWOC PUBLIC LIBRARY:</b>				<b>9.00</b>					
<b>PEWAUKEE UTILITY</b>									
<b>Approved</b>									
13111	PEWAUKEE UTILITY	07102025	LIBRARY/W ATER SEWER FIRE	585.65	07/10/2025	08/10/2025			Approved
<b>Total PEWAUKEE UTILITY:</b>				<b>585.65</b>					
<b>RHYME BUSINESS PRODUCTS, LLC</b>									
<b>Approved</b>									
13202	RHYME BUSINESS PRODUCTS, LLC	AR853319	LIBRARY/C OPIES 2025.07.23 TO 2025.08.22	125.11	07/21/2025	08/21/2025			Approved
<b>Total RHYME BUSINESS PRODUCTS, LLC:</b>				<b>125.11</b>					
<b>TAYLOR COMPUTER SERVICES, INC</b>									
<b>Approved</b>									
810	TAYLOR COMPUTER SERVICES, INC	28130	LIBRARY/M ANAGED SERVICES FOR JULY 2025 + OTHER	743.75	06/30/2025	07/30/2025			Approved

APIInvoiceApprovalDepartment.DepartmentName LIBRARY AND GeneralLedgerPeriod.GLPeriod 725

Vendor	Vendor Name	Invoice Number	Description	Invoice Amount	Invoice Date	Due Date	Batch	GL Period	Status
<b>Total TAYLOR COMPUTER SERVICES, INC:</b>				<u>743.75</u>					
<b>THE ENCHANTED STORYBOOK CO.</b>									
<b>Approved</b>									
13357	THE ENCHANTED STORYBOOK CO.	1012-01	LIBRARY/S UMMER PROGRAMS KIWANIS	225.00	06/25/2025	07/02/2025			Approved
<b>Total THE ENCHANTED STORYBOOK CO.:</b>				<u>225.00</u>					
<b>WALDEN, NEITZKE &amp; KUHARY, SC</b>									
<b>Approved</b>									
11855	WALDEN, NEITZKE & KUHARY, SC	07467	LIBRARY/L EGAL SVCS JUNE-JULY 2025	420.00	07/07/2025	08/07/2025			Approved
<b>Total WALDEN, NEITZKE &amp; KUHARY, SC:</b>				<u>420.00</u>					
<b>WAUKESHA PUBLIC LIBRARY</b>									
<b>Approved</b>									
2657	WAUKESHA PUBLIC LIBRARY	IWPL0010688722	LIBRARY/R EIMBURSE MENT FOR REPLACME NT	21.85	07/29/2025	08/29/2025			Approved
<b>Total WAUKESHA PUBLIC LIBRARY:</b>				<u>21.85</u>					
<b>Total:</b>				<u>32133.44</u>					

<b>LOCAL GOVERNMENT INVESTMENT POOL</b>
---

## MONTHLY STATEMENT of ACCOUNTS

**Department of Administration**

July 2025

State of Wisconsin  
P.O. Box 7871 - Madison WI 53707  
Phone: 608.266.3711  
Fax: 608.223.6578  
Depositor No. 867171

PEWAUKEE, VILLAGE OF

235 HICKORY ST  
PEWAUKEE, WI 53072-3533

<b>01) GENERAL</b>	<b>\$9,859,918.35</b>
<b>02) CAP EXP &amp; CONST PROJ</b>	<b>\$521,476.09</b>
<b>03) SEWER DEBT REPLACE</b>	<b>\$2,730,639.29</b>
<b>04) SEWER INVESTMENTS</b>	<b>\$1,259,696.11</b>
<b>05) WTR UTIL INVESTMENT</b>	<b>\$629,704.96</b>
<b>06) TIF RELATED HOLDING</b>	<b>\$163,790.42</b>
<b>07) LAIMON DONATION/LAKESIDE PARK</b>	<b>\$270,054.88</b>
<b>08) CEMETARY PERPETUAL</b>	<b>\$36,978.49</b>
<b>09) SEWER HOOKUP FEES</b>	<b>\$1,941,907.53</b>
<b>12) WATER HOOKUP FEES</b>	<b>\$280,930.57</b>
<b>16) LIBRARY</b>	<b>\$101,228.47</b>

<b>TOTAL</b>	<b>\$17,796,325.16</b>
--------------	------------------------

Date	Type	Memo	Deposits	Withdrawals	Balance
<b>Acct# 01</b>	<b>GENERAL</b>			<b>Beginning Balance</b>	<b>\$11,933,625.59</b>
07/07/2025	Deposit - Direct Aids	DOT MUNI TRN AD	\$120,714.88		\$12,054,340.47
07/10/2025	Withdraw - Wire	TRANSFER TO COVER PAYABLES 7/9/2025		(\$400,000.00)	\$11,654,340.47
07/11/2025	Deposit - Direct Aids	Fire Dues 2025-Dept Safety & Pro	\$55,261.49		\$11,709,601.96
07/25/2025	Withdraw - Wire	TRANSFER TO COVER PAYABLES 7/25/2025		(\$2,000,000.00)	\$9,709,601.96
07/28/2025	Deposit - Direct Aids	REV SHARED REV	\$62,372.04		\$9,771,974.00
07/28/2025	Deposit - Direct Aids	REV COMPUTER	\$14,607.78		\$9,786,581.78
07/28/2025	Deposit - Direct Aids	REV COMPUTER	\$2,149.93		\$9,788,731.71
07/28/2025	Deposit - Direct Aids	ETF INTERFACE	\$29,136.28		\$9,817,867.99
07/31/2025	Interest	INT Jul 25 4.36%	\$42,050.36		\$9,859,918.35
	<b>Account Total</b>		<b>\$326,292.76</b>	<b>(\$2,400,000.00)</b>	<b>\$9,859,918.35</b>
<b>Acct# 02</b>	<b>CAP EXP &amp; CONST PROJ</b>			<b>Beginning Balance</b>	<b>\$519,550.69</b>
07/31/2025	Interest	INT Jul 25 4.36%	\$1,925.40		\$521,476.09
	<b>Account Total</b>		<b>\$1,925.40</b>	<b>\$0.00</b>	<b>\$521,476.09</b>
<b>Acct# 03</b>	<b>SEWER DEBT REPLACE</b>			<b>Beginning Balance</b>	<b>\$2,720,557.20</b>
07/31/2025	Interest	INT Jul 25 4.36%	\$10,082.09		\$2,730,639.29
	<b>Account Total</b>		<b>\$10,082.09</b>	<b>\$0.00</b>	<b>\$2,730,639.29</b>
<b>Acct# 04</b>	<b>SEWER INVESTMENTS</b>			<b>Beginning Balance</b>	<b>\$1,255,045.05</b>
07/31/2025	Interest	INT Jul 25 4.36%	\$4,651.06		\$1,259,696.11
	<b>Account Total</b>		<b>\$4,651.06</b>	<b>\$0.00</b>	<b>\$1,259,696.11</b>
<b>Acct# 05</b>	<b>WTR UTIL INVESTMENT</b>			<b>Beginning Balance</b>	<b>\$627,379.96</b>
07/31/2025	Interest	INT Jul 25 4.36%	\$2,325.00		\$629,704.96

	<b>Account Total</b>		<b>\$2,325.00</b>	<b>\$0.00</b>	<b>\$629,704.96</b>
<b>Acct# 06</b>	<b>TIF RELATED HOLDING</b>			<b>Beginning Balance</b>	<b>\$163,185.67</b>
07/31/2025	Interest	INT Jul 25 4.36%	\$604.75		\$163,790.42
	<b>Account Total</b>		<b>\$604.75</b>	<b>\$0.00</b>	<b>\$163,790.42</b>
<b>Acct# 07</b>	<b>LAIMON DONATION/LAKESIDE PARK</b>			<b>Beginning Balance</b>	<b>\$269,057.78</b>
07/31/2025	Interest	INT Jul 25 4.36%	\$997.10		\$270,054.88
	<b>Account Total</b>		<b>\$997.10</b>	<b>\$0.00</b>	<b>\$270,054.88</b>
<b>Acct# 08</b>	<b>CEMETARY PERPETUAL</b>			<b>Beginning Balance</b>	<b>\$36,841.96</b>
07/31/2025	Interest	INT Jul 25 4.36%	\$136.53		\$36,978.49
	<b>Account Total</b>		<b>\$136.53</b>	<b>\$0.00</b>	<b>\$36,978.49</b>
<b>Acct# 09</b>	<b>SEWER HOOKUP FEES</b>			<b>Beginning Balance</b>	<b>\$1,934,737.60</b>
07/31/2025	Interest	INT Jul 25 4.36%	\$7,169.93		\$1,941,907.53
	<b>Account Total</b>		<b>\$7,169.93</b>	<b>\$0.00</b>	<b>\$1,941,907.53</b>
<b>Acct# 12</b>	<b>WATER HOOKUP FEES</b>			<b>Beginning Balance</b>	<b>\$279,893.32</b>
07/31/2025	Interest	INT Jul 25 4.36%	\$1,037.25		\$280,930.57
	<b>Account Total</b>		<b>\$1,037.25</b>	<b>\$0.00</b>	<b>\$280,930.57</b>
<b>Acct# 16</b>	<b>LIBRARY</b>			<b>Beginning Balance</b>	<b>\$100,854.71</b>
07/31/2025	Interest	INT Jul 25 4.36%	\$373.76		\$101,228.47
	<b>Account Total</b>		<b>\$373.76</b>	<b>\$0.00</b>	<b>\$101,228.47</b>

• There are no minimum or maximum dollar limits for deposits and withdrawals. However, to enhance investment performance for all LGIP participants, notify the LGIP Administrator, at least one day prior to the transaction date, of any deposits and/or withdrawals of \$10 million or more.

• There has been changes to your account security. The Local Government Investment Pool (LGIP) has a new security measure to protect your account. Your LGIP Account will be assigned a verification code to protect your account from unauthorized use. The verification code is used to validate your full user rights account access. To assist us in this new security measure, please make note of what your verification code is. For users with full user rights access, you can find your verification code on the LGIP website under your account settings. Please provide this verification code when calling LGIP. If you do not have online access, please contact the LGIP Administrator at [lgip@wisconsin.gov](mailto:lgip@wisconsin.gov).

• As a user of your LGIP account online, please ensure your user access is updated. If you would like to verify who has user access to your account, please email the administrator at [LGIP@wisconsin.gov](mailto:LGIP@wisconsin.gov)

## Pewaukee Public Library - Monthly Statistics 2025

	Jan	Feb	Mar	April	May	June	July	Aug	Sept	Oct	Nov	Dec	Year to date	%
<b>Circulation - ALL</b>														
2023	24356	23294	27214	24363	24324	31204	31713	30545	24531	25520	24240	22072	313376	110.66%
2024	27030	25093	27741	26423	24802	29343	33221	28671	24717	23933	23536	22784	317294	101.25%
2025	<b>25546</b>	<b>23468</b>	<b>27323</b>	<b>25880</b>	<b>24601</b>	<b>30919</b>	<b>32449</b>						<b>190186</b>	<b>98.21%</b>
<b>Circulation - Print and A/V</b>														
2023	20252	19604	23031	20493	20217	27334	27722	26314	20342	20869	20227	18682	265087	103.40%
2024	22224	20591	23043	21936	20181	24818	28559	24014	20107	19320	18971	18157	261921	98.81%
2025	<b>20181</b>	<b>18557</b>	<b>21880</b>	<b>20813</b>	<b>19503</b>	<b>25807</b>	<b>27066</b>						<b>153807</b>	<b>95.32%</b>
<b>Circulation - Overdrive</b>														
2023	3881	3481	3946	3655	3827	3602	3732	3928	3861	4320	3707	2953	44893	118.82%
2024	4288	3946	4190	3898	4164	4097	4229	4183	4107	4119	4108	4154	49483	110.22%
2025	<b>4787</b>	<b>4418</b>	<b>4921</b>	<b>4557</b>	<b>4522</b>	<b>4587</b>	<b>4856</b>						<b>32648</b>	<b>113.31%</b>
<b>Circulation - Hoopla</b>														
Flex 2023	0	0	0	0	0	0	0	0	0	0	0	42	42	
Instant 2023	223	209	237	215	280	268	259	303	328	331	306	395	3354	
Total 2023	223	0	237	215	280	268	259	303	328	331	306	437	3187	
Flex 2024	67	95	99	112	122	118	126	134	152	130	123	135	1413	6632.29%
Instant 2024	451	461	409	477	335	310	307	340	351	364	334	338	4477	133.48%
Total 2024	518	556	508	589	457	428	433	474	503	494	457	473	5890	184.81%
Flex 2025	<b>188</b>	<b>154</b>	<b>161</b>	<b>158</b>	<b>191</b>	<b>161</b>	<b>159</b>						<b>1172</b>	<b>158.59%</b>
Instant 2025	<b>390</b>	<b>339</b>	<b>361</b>	<b>352</b>	<b>385</b>	<b>364</b>	<b>368</b>						<b>2559</b>	<b>93.05%</b>
Total 2025	<b>578</b>	<b>493</b>	<b>522</b>	<b>510</b>	<b>576</b>	<b>525</b>	<b>527</b>	<b>0</b>	<b>0</b>	<b>0</b>	<b>0</b>	<b>0</b>	<b>3731</b>	<b>106.94%</b>
<b>% of Circulation Digital</b>														
2023	16.85%	14.94%	15.37%	15.88%	16.88%	12.40%	12.58%	13.85%	17.08%	18.22%	16.56%	15.36%	15.34%	
2024	17.78%	17.94%	16.94%	16.98%	18.63%	15.42%	14.03%	16.24%	18.65%	19.27%	19.40%	20.31%	17.45%	
2025	<b>21.00%</b>	<b>20.93%</b>	<b>19.92%</b>	<b>19.58%</b>	<b>20.72%</b>	<b>16.53%</b>	<b>16.59%</b>						<b>19.13%</b>	
<b>LSER (LIBRARY SERVICES EFFORT RATIO)</b>														
2023	87.99%	89.36%	91.35%	91.52%	87.75%	90.87%	91.45%	91.99%	89.18%	89.65%	92.00%	92.76%	90.53%	
2024	96.86%	90.08%	94.91%	92.91%	91.70%	88.67%	87.21%	89.14%	92.84%	92.31%	89.63%	88.06%	90.99%	
2025	<b>90.17%</b>	<b>85.90%</b>	<b>87.83%</b>	<b>89.71%</b>	<b>88.38%</b>	<b>89.28%</b>	<b>88.11%</b>						<b>88.50%</b>	
<b>Circulation - Check Ins</b>														
2024	14,241	13,691	14,049	15,745	15,630	14,855	19,188	16,651	14,519	13,388	12,158	13,857	177,972	
2025	<b>13,041</b>	<b>12,275</b>	<b>14,570</b>	<b>13,688</b>	<b>12,986</b>	<b>15,871</b>	<b>18,352</b>						<b>100,783</b>	<b>93.84%</b>
<b>Library Visits</b>														
Monthly total 2024	9456	9532			1701	6230	5995	4589	3981	4832	3822	3599	53737	50.29%
Daily average 2024	394	381			243	249	231	177	166	186	159	156	234	64.16%
Monthly total 2025	<b>4500</b>	<b>4230</b>	<b>4735</b>	<b>4995</b>	<b>4034</b>	<b>6467</b>	<b>6392</b>						<b>35353</b>	<b>107.41%</b>
Daily average 2025	<b>173</b>	<b>176</b>	<b>175</b>	<b>185</b>	<b>208</b>	<b>259</b>	<b>246</b>							
<b>Reference Transactions</b>														
2024	680	627	727	716	477	950	989	700	509	550	435	436	7796	62.79%
2025	<b>590</b>	<b>559</b>	<b>580</b>	<b>564</b>	<b>493</b>	<b>1098</b>	<b>859</b>						<b>4743</b>	<b>91.81%</b>

## Pewaukee Public Library - Monthly Statistics 2025

	Jan	Feb	Mar	April	May	June	July	Aug	Sept	Oct	Nov	Dec	Year to date	%	
<b>New Library Cards Issued</b>															
2024	129	129	120	98	97	137	113	95	100	99	73	59	1249	94.91%	
2025	114	81	113	115	94	169	133						819	99.51%	
<b>Meetings Room Usage</b>															
2024	44	47	55	75	48	52	73	29	54	67	54	32	630	119.54%	
2025	58	68	61	80	56	62	68						453	114.97%	
<b>Study Room Usage</b>															
2024	139	170	133	159	131	139	159	131	120	167	133	124	1705	159.20%	
2025	153	182	157	154	151	149	45						991	96.21%	
<b>Uses of Public Wireless Internet</b>															
2024	1210	1050		451	1149	1401	1318	931	1234	1434	1143	993	12314	97.73%	
2025	348	4503	5121	5627	5219	4265	5247						30330	461.01%	
<b>Use of Public Internet Computers</b>															
2024	457	513	474	509	282	364	380	443	377	395	339	341	4874	99.41%	
2025	379	N/A	431	435	369	384	391						2389	80.19%	
<b>Website Visits</b>															
2024	14744	14903	19352	16068	16870	15999	15308	13505	13331	14730	15204	16575	186589	103.93%	
2025	15180	14268	14013	20555	15063	15180	19116						113375	100.12%	
<b>Children's Programs (0-5)</b>															
# programs	2024	11	15	10	15	4	10	22	3	8	17	14	4	133	91.73%
Attendance	2024	568	712	732	724	165	377	982	87	350	693	660	192	6242	133.08%
# programs	2025	8	14	11	17	6	15	19						90	3363.64%
Attendance	2025	291	676	494	771	319	728	783						4062	95.35%
<b>Children's Programs (6-11)</b>															
# programs	2024	3	4	5	4	4	11	22	0	4	5	4	8	74	77.89%
Attendance	2024	75	86	202	308	261	932	809	0	150	276	132	322	3553	78.33%
# programs	2025	4	5	5	7	6	17	18						62	116.98%
Attendance	2025	86	144	126	271	849	1198	678						3352	125.40%
<b>Young Adult Programs (12-18)</b>															
# programs	2024	4	4	2	2	3	2	2	1	1	1	3	1	26	108.33%
Attendance	2024	24	43	11	16	138	75	29	34	11	11	27	10	429	222.28%
# programs	2025	2	2	3	3	4	1	4						19	100.00%
Attendance	2025	12	19	18	26	159	2	68						304	90.48%
<b>Adult Programs (19+)</b>															
# programs	2024	10	10	10	11	9	12	10	10	15	12	10	7	126	131.25%
Attendance	2024	117	145	167	217	176	214	124	154	279	192	171	87	2043	100.54%
# programs	2025	6	9	12	13	13	10	9						72	100.00%
Attendance	2025	35	118	206	224	220	139	108						1050	90.52%

## Pewaukee Public Library - Monthly Statistics 2025

	Jan	Feb	Mar	April	May	June	July	Aug	Sept	Oct	Nov	Dec	Year to date	%
<b>General Interest Program</b>														
# programs 2024	0	0	0	0	0	3	1	0	1	1	0	0	6	300.00%
Attendance 2024	0	0	0	0	0	515	112	0	41	22	0	0	690	142.27%
# programs 2025	0	0	1	0	0	2	0						3	100.00%
Attendance 2025	0	0	120	0	0	404	0						524	101.75%
<b>Children's Self-Directed Activities (0-5) (includes summer reading participation)</b>														
# programs 2024	0	0	0	0	0	0	0	1	0	0	0	0	1	50.00%
Attendance 2024	0	0	0	0	0	0	0	148	0	0	0	0	148	217.65%
# programs 2025	0	0	0	0	0	0	2						2	#DIV/0!
Attendance 2025	0	0	0	0	0	0	125						125	#DIV/0!
<b>Children's Self-Directed Activities (6-11) (includes summer reading participation)</b>														
# programs 2024	2	1	1	1	0	0	0	1	0	0	1	1	8	26.67%
Attendance 2024	100	32	155	32	0	0	0	660	0	0	181	58	1218	48.43%
# programs 2025	0	1	1	2	1	0	0						5	100.00%
Attendance 2025	0	15	121	38	20	0	0						194	60.82%
<b>Young Adult Self-Directed Activities (12-18) (includes summer reading participation)</b>														
# programs 2024	3	2	3	3	4	4	3	4	0	3	4	3	36	144.00%
Attendance 2024	80	68	66	187	33	225	148	280	0	112	168	112	1479	187.45%
# programs 2025	4	4	3	4	3	3	5						26	136.84%
Attendance 2025	104	144	95	110	92	284	241						1070	162.37%
<b>Adult Self-Directed Activities (19+) (includes summer reading participation)</b>														
# programs 2024	3	4	4	0	0	0	0	1	0	0	0	1	13	118.18%
Attendance 2024	297	358	409	0	0	0	0	249	0	0	0	52	1365	137.05%
# programs 2025	2	4	4	0	0	0	0						10	90.91%
Attendance 2025	196	366	375	0	0	0	0						937	88.06%
<b>Other Self-Directed Activities (All Ages) (includes summer reading participation)</b>														
# programs 2024	0	0	0	0	0	2	1	3	0	0	0	1	7	175.00%
Attendance 2024	0	0	0	0	0	612	242	209	0	0	0	16	1079	178.35%
# programs 2025	0	0	0	0	0	2	1						3	150.00%
Attendance 2025	0	0	0	0	0	357	165						522	85.29%

**Subject:** Proposed 2026 Budget Development Timeline

As we begin preparations for the 2026 fiscal year budget, the following timeline outlines key dates and milestones in the budget development and review process.

The proposed timeline is as follows:

Item	Month	Date
Deadline for Department Heads to Submit Proposed Budgets	August	August 15, 2025
Department Head Budget Meetings with Mayor	September	September 10, 2025
Finance Committee Budget Review Meeting	September	September 26, 2025
Budget Workshop with Common Council	October	October 13, 2025
Additional Budget Workshop <i>(if necessary)</i>	October	October 27, 2025
Public Hearing on Proposed Budget	November	November 3, 2025

This schedule is designed to allow for ample review and discussion at both the staff, alderpersons, and mayor, as well as to provide an opportunity for public input before final budget adoption. Please note that dates are subject to adjustment as necessary to accommodate scheduling needs or unforeseen circumstances.

Should any members of the Council have questions or suggestions regarding the proposed timeline, please don't hesitate to reach out.

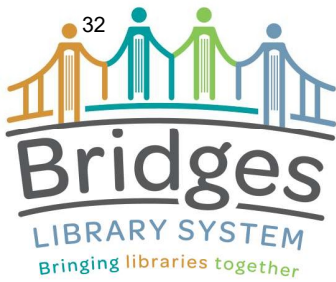

741 N. Grand Ave., #210  
Waukesha, WI 53186

P 262.896.8080  
W bridgeslibrarysystem.org

To: Waukesha County Library Directors  
From: Brittany Larson, Bridges Library System Director  
Re: Minimum Municipal Appropriation to Exempt from County Library Tax  
Date: August 15, 2025

Please see the chart below for your municipality's necessary minimum library appropriation for 2026 to qualify for exemption from the county library tax. The calculation for each municipality's minimum amount is based on the county library tax rate from the previous year and the [equalized assessed value](#) for each municipality in the current year. The county library tax rate decreased from \$0.000201553 to \$0.000201512 from the previous year. Please contact me if you have any questions.

Library	2025 Equalized Value (less TID) in Municipalities with Libraries	% Change in Equalized Value from Prior Year	County Library Tax Rate (for 2025 levy)	2026 Minimum Municipal Library Appropriation*	% Change in Minimum Appropriation from Prior Year	Previous Year Minimum Appropriation
BIG BEND	\$284,297,700	9.06%	\$0.000201512	\$57,289	9.04%	\$52,539
BROOKFIELD	\$10,432,335,700	7.16%	\$0.000201512	\$2,102,240	7.13%	\$1,962,257
BUTLER	\$360,596,100	7.69%	\$0.000201512	\$72,664	7.66%	\$67,491
DELAFIELD	\$2,667,384,100	9.73%	\$0.000201512	\$537,510	9.70%	\$489,966
Eagle Village*	\$338,170,100	7.91%	\$0.000201512	\$68,145	7.88%	\$63,166
Eagle Town*	\$887,500,900	5.07%	\$0.000201512	\$178,842	5.05%	\$170,244
ELM GROVE	\$1,783,180,000	5.92%	\$0.000201512	\$359,332	5.90%	\$339,306
HARTLAND	\$2,320,843,300	11.02%	\$0.000201512	\$467,678	11.00%	\$421,327
MENOMONEE FALLS	\$8,256,550,700	10.94%	\$0.000201512	\$1,663,793	10.91%	\$1,500,090
MUKWONAGO	\$1,408,343,300	9.04%	\$0.000201512	\$283,798	9.01%	\$260,329
MUSKEGO	\$5,423,777,200	10.60%	\$0.000201512	\$1,092,956	10.58%	\$988,401
MERTON	\$3,032,449,600	9.32%	\$0.000201512	\$611,075	9.30%	\$559,068
NEW BERLIN	\$8,259,983,700	3.91%	\$0.000201512	\$1,664,485	3.89%	\$1,602,146
OCONOMOWOC	\$4,112,435,700	10.07%	\$0.000201512	\$828,705	10.05%	\$753,044
Pewaukee Village*	\$1,477,625,000	8.84%	\$0.000201512	\$297,759	8.82%	\$273,631
Pewaukee City*	\$5,228,633,000	5.17%	\$0.000201512	\$1,053,632	5.15%	\$1,002,060
Sussex	\$2,413,827,600	9.53%	\$0.000201512	\$486,415	9.51%	\$444,179
WAUKESHA	\$10,498,558,100	11.40%	\$0.000201512	\$2,115,584	11.37%	\$1,899,537

\*Joint libraries may use an alternative calculation described in Wis. Stats. 43.64 (2) (c).



To: Department Heads

From: Matt Heiser  
Village Administrator

Date: July 24, 2025

Re: 2026 Budget Instructions

It is budget season once again. The most wonderful time of the year.

Last year we attempted to use MVP. There were instances where I could not view a few accounts and there were some sub-budgets I could not edit. As a result, I would like to just use MS Excel for dept heads to submit their budgets. The Board will also review spreadsheets in the budget process. Last year the feedback I received from the Board was they appreciated spreadsheets for their reviews. You can download the 2025 budget and its current status into MS Excel from MVP. I can assist you with that if you would like. The joint departments, Library and Park & Rec, can continue to use the formats that you have in the past to suit your Boards.

When you export the budget to XLS it will look like this:

July 24, 2025 10:59 AM

End:GLPeriod 625

Account Number	Account Title	YTD	Budget	Variance	% Budget
10 - GENERAL FUND					
10-00-17100-000-000	PREPAID EXPENSES(A)	109,228.46	.00	-109,228.46	100.00%
<b>Total Asset:</b>		<b>109,228.46</b>	<b>.00</b>	<b>-109,228.46</b>	
10-00-51100-000-000	VILLAGE BOARD(E)	14,993.27	29,300.00	14,306.73	51.17%
10-00-51100-000-130	VILLAGE BOARD FRINGE BENEFITS(E)	1,147.09	2,203.00	1,055.91	52.06%
10-00-51110-000-000	BOARD OF REVIEW(E)	.00	.00	.00	100.00%
10-00-51120-000-000	PLAN COMMISSION(E)	32,386.80	11,436.00	-20,950.80	283.20%
10-00-51120-000-100	PLANNING ENG CONSULTING SERV(E)	-26,980.15	10,000.00	36,980.15	-269.80%
10-00-51121-000-000	POLICE COMMISSION(E)	.00	.00	.00	100.00%
10-00-51200-000-110	MUNICIPAL JUDGE SALARY(E)	19,196.46	35,416.00	16,219.54	54.20%
10-00-51200-000-130	MUNICIPAL JUDGES BENEFITS(E)	5,783.06	9,983.00	4,199.94	57.92%
10-00-51200-000-140	MUNICIPAL JUDGES EXPENSES(E)	10,988.06	19,549.00	8,560.94	56.20%
10-00-51300-000-000	LEGAL COUNSEL-VILLAGE ATTORNEY(E)	35,515.00	59,000.00	23,485.00	60.19%
10-00-51300-000-110	MUNICIPAL COURT ATTORNEY EXP(E)	10,527.00	18,000.00	7,473.00	58.48%
10-00-51300-000-120	SPECIAL LEGAL(E)	.00	.00	.00	100.00%
10-00-51300-000-140	EXPENSES - RECODIFICATION(E)	.00	5,200.00	5,200.00	0.00%
10-00-51320-000-000	LABOR ATTORNEY(E)	2,196.00	7,000.00	4,804.00	31.37%
10-00-51400-000-110	VILLAGE ADMINISTRATOR SALARY(E)	48,643.99	107,120.00	58,476.01	45.41%
10-00-51400-000-130	VILL. ADMIN. FRINGE BENEFITS(E)	20,688.18	40,254.00	19,565.82	51.39%
10-00-51400-000-140	ADMINISTRATOR EXPENSES(E)	12,820.28	3,654.00	-9,166.28	350.83%
10-00-51420-000-110	CLERK OFFICE SALARY & WAGES(E)	68,802.41	151,474.00	82,671.59	45.42%
10-00-51420-000-130	CLERK OFFICE FRINGE BENEFITS(E)	13,849.31	33,000.00	19,150.69	41.96%
10-00-51420-000-140	CLERKS OFFICE EXPENSES(E)	22,666.58	38,860.00	16,193.42	58.32%
10-00-51440-000-000	ELECTIONS(E)	7,175.46	24,334.00	17,158.54	29.48%
10-00-51440-000-130	ELECTIONS - BENEFITS(E)	145.50	600.00	454.50	24.25%

Please add a column for 2026 like this:

July 24, 2025 10:59 AM

End.GL Period 625						
Account Number	Account Title	YTD	Budget	Variance	% Budget	2026
110 - GENERAL FUND						
110-00-17100-000-000	PREPAID EXPENSES(A)	109,228.46	.00	-109,228.46	100.00%	
<b>Total Asset:</b>		<b>109,228.46</b>	<b>.00</b>	<b>-109,228.46</b>		
110-00-51100-000-000	VILLAGE BOARD(E)	14,993.27	29,300.00	14,306.73	51.17%	
110-00-51100-000-130	VILLAGE BOARD FRINGE BENEFITS(E)	1,147.09	2,203.00	1,055.91	52.06%	
110-00-51110-000-000	BOARD OF REVIEW(E)	.00	.00	.00	100.00%	
110-00-51120-000-000	PLAN COM.MISSION(E)	32,386.80	11,436.00	-20,950.80	283.20%	
110-00-51120-000-100	PLANNING ENG CONSULTING SERV(E)	-26,980.15	10,000.00	36,980.15	-269.80%	
110-00-51121-000-000	POLICE COMMISSION(E)	.00	.00	.00	100.00%	
110-00-51200-000-110	MUNICIPAL JUDGE SALARY(E)	19,196.46	35,416.00	16,219.54	54.20%	
110-00-51200-000-130	MUNICIPAL JUDGES BENEFITS(E)	5,783.06	9,983.00	4,199.94	57.92%	
110-00-51200-000-140	MUNICIPAL JUDGES EXPENSES(E)	10,988.06	19,549.00	8,560.94	56.20%	
110-00-51300-000-000	LEGAL COUNSEL-VILLAGE ATTORNEY(E)	35,515.00	59,000.00	23,485.00	60.19%	
110-00-51300-000-110	MUNICIPAL COURT ATTORNEY EXP(E)	10,527.00	18,000.00	7,473.00	58.48%	
110-00-51300-000-120	SPECIAL LEGAL(E)	.00	.00	.00	100.00%	
110-00-51300-000-140	EXPENSES - RECODIFICATION(E)	.00	5,200.00	5,200.00	0.00%	
110-00-51320-000-000	LABOR ATTORNEY(E)	2,196.00	7,000.00	4,804.00	31.37%	
110-00-51400-000-110	VILLAGE ADMINISTRATOR SALARY(E)	48,643.99	107,120.00	58,476.01	45.41%	
110-00-51400-000-130	VILL. ADMIN. FRINGE BENEFITS(E)	20,688.18	40,254.00	19,565.82	51.39%	
110-00-51400-000-140	ADMINISTRATOR EXPENSES(E)	12,820.28	3,654.00	-9,166.28	350.83%	
110-00-51420-000-110	CLERK OFFICE SALARY & WAGES(E)	68,802.41	151,474.00	82,671.59	45.42%	
110-00-51420-000-130	CLERK OFFICE FRINGE BENEFITS(E)	13,849.31	33,000.00	19,150.69	41.96%	
110-00-51420-000-140	CLERKS OFFICE EXPENSES(E)	22,666.58	38,860.00	16,193.42	58.32%	
110-00-51440-000-000	ELECTIONS(E)	7,175.46	24,334.00	17,158.54	29.48%	
110-00-51440-000-130	ELECTIONS - BENEFITS(E)	145.50	600.00	454.50	24.25%	

Please prepare your budget under the following guidelines:

1. The minimum amount needed to maintain current level of services; not including wages and benefits.
2. Amounts over the minimum needed are allowed if it is related to employee/public safety or to capture efficiencies.
3. Please have the detail that adds into the total for different accounts, including membership in professional association and training.
4. Please have a list of items you did not include in order to comply with these guidelines

State law limits levy increases to net new construction. Those numbers will be released by the state in mid-August. This will determine the amount the budget can increase for the Village as a whole.

I will review your requests with you before they go to the Board.

The following is a potential time-line:

- August 15: Requests are due
- August 19: Board schedules budget workshops
- September 2: Initial review of draft budget (Police and Library)
- September 16: General Administration and Park and Rec
- October 7: DPW, Water, Sewer and Storm water facilities
- October 21: Continued Discussion
- November 4: Continued Discussion
- November 18: Public hearing and action on 2026 budget



**Pewaukee Public Library  
2026 Budget Details and  
Administrative Recommendations  
August 20, 2025**

(blank)

## Summary

In 2026, the Pewaukee Public Library remains dedicated to delivering high-quality services to residents of both the City and Village of Pewaukee, as well as to all others who choose to use our resources including Waukesha County residents from communities with or without a public library and other Wisconsin residents.

Our plans for 2026 include continuing to offer and expand:

- A robust schedule of programs for both adults and children
- High-quality collections in print and digital formats
- A clean, safe facility where patrons can work quietly or collaborate with others
- Comprehensive computer services, including Wi-Fi, public internet stations, and printing/copying
- Knowledgeable, professional staff ready to assist with a wide range of informational needs
- Outreach services to local senior living centers
- Community spaces for public meetings

To support these plans, along with the full range of services we provide, I have prepared the proposed 2026 budget for your review and consideration.

## Expenditures

Total expenditures for 2026 are projected at **\$1,337,464**, reflecting a **decrease of \$7,614 (0.57%)** compared to the 2025 budget. However, this decrease is somewhat misleading, as the 2025 budget included **\$25,000** for several special projects (Outlay) funded by the Library's fund balance—not by municipal contributions or library revenues. The 2026 budget does not include any similar special project allocations.

When these one-time 2025 project expenses are excluded, the adjusted year-over-year comparison shows that the 2026 proposed budget represents an **increase of \$17,386 (1.32%)**. This increase is largely driven by ongoing inflationary pressures and annual rises in payroll and benefit costs, which continue to impact general operating expenses.

### **Maintenance of Effort (MOE) Minimums for PPL – 2026 Budget / 2027 Standards**

The proposed 2026 budget meets all Maintenance of Effort (MOE) standards required by Waukesha County that are listed below. As a result, both the Village of Pewaukee and the City of Pewaukee will remain eligible to exempt their residents from the Waukesha County Library Tax as long as they also approve the required minimum appropriation.

<b>Standard</b>	<b>Minimum Standard</b>	<b>2026 Budget</b>
<b>Materials Expenditure</b>	<b>\$138,662</b>	<b>\$139,000</b>
<b>FTE Staff</b>	<b>13.24</b>	<b>13.27</b>
<b>Hours Open Per Week</b>	<b>57</b>	<b>59</b>
<b>Collection Size</b>	<b>101,000</b>	<b>101,000</b>
<b>Public Internet Devices</b>	<b>13</b>	<b>13</b>

### **Description<sup>38</sup> of Significant Changes: Expenditures.**

This section provides explanations for any expenditure increases or decreases of \$1,000 or more.

#### *Library Salaries. (Increase of \$20,590 or 2.99%)*

The proposed 2026 budget maintains the same staffing positions and levels as in 2025. The Library employs 5 full-time librarians, 2 part-time librarians, and 16 part-time support staff members. Salaries represent the largest portion of the budget, accounting for 53% of total expenditures in the 2026 proposal. Compared to other City and Village employees, Library staff consistently rank at the lowest end of the municipal salary scales. As a result, annual pay adjustments are essential to help make Library salaries more competitive within the labor market.

- This budget supports 13.275 FTE positions, aligning with the 2026 Maintenance of Effort (MOE) standard of 13.24 FTE.
- It includes a 2% cost-of-living adjustment for full-time employees and part-time librarians, along with a merit increase pool of 0–2%.
- All other staff are budgeted to receive a \$1.00 per hour wage increase.
- The overall increase is partially offset by lower starting salaries for new hires in 2025.

#### *Benefits and Payroll Taxes (Decrease of \$3,249 or 1.45%)*

The proposed 2026 budget maintains the same benefit levels as in 2025. The Library provides a full benefits package to its 5 full-time librarians. 2 part-time librarians and 1 support staff member currently qualify for prorated benefits. The Library also employs 17 part-time support staff members who do not receive benefits, despite working year-round. Benefits represent the second-largest portion of the budget, accounting for 16% of total expenditures in the 2026 proposal. The Library remains the largest municipal department to employ a significant number of part-time, non-benefited staff.

- The Wisconsin Retirement System (WRS) contribution rate will increase from 6.95% to 7.2% in 2026. 8 employees are enrolled in WRS.
- A 10% increase in health insurance costs is projected, based on current staff elections. Final rates are not yet available, and costs may change depending on staff selections during the open enrollment period.
- The overall decrease in this line item is due to adjusted benefit elections for new hires in 2025.

#### *Materials/Municipal Contribution (Increase of \$2,430 or 1.92%)*

- This budget line represents the municipal contribution to the materials budget. When combined with the Friends commitment of \$7,000 to support the Library's explore pass program and library of things and Bridges e-materials grant for \$3,263, the total materials budget will be \$139,000. This allocation will align with the 2026 MOE standard of \$138,662.
- The increase in this line item as compared to 2025 is due to an increase in population from 24,408 in 2024 to 24,507 in 2025. This increase resulted in a corresponding adjustment in the MOE minimum from 2025 to 2026.

#### *Professional Services (Increase of \$1,079 or 2.35%)*

- All line items are based on actual 2024 expenditures
- In 2024, the actual cost of property insurance was \$14,397, representing an increase of \$1,697. This budget has been adjusted to reflect the anticipated continued increase in property insurance costs.

*Library Annual Municipal Fees (Decrease of \$1,582 or 41.83%)*

- The Library is exempt from the Fire and EMS fee; therefore, this expense has been removed from the budget.

*Donations (Decrease of \$1,000 or 12.5%)*

- The Friends' contribution has been reduced by \$1,000 to align with the actual cost of Explore Passes purchased by the Library and to support ongoing contributions toward the purchase and upgrade of the Library of Things collection.

*Library Outlay (Decrease of \$25,000 or 100%)*

- This budget does not allocate funds for special building maintenance projects or equipment upgrades in 2026.

**Revenues**

Total revenues required to support the proposed 2026 operating budget are **\$1,337,464**, reflecting a **decrease of \$8,114 (0.6%)** compared to 2025. However, similar to expenditures, this decrease is somewhat misleading. The 2025 budget included a one-time use of \$57,211 from the Library's fund balance to balance the budget. The 2026 proposed budget does not rely on any fund balance usage.

When this one-time 2025 fund balance revenue is excluded, the adjusted year-over-year comparison shows that the 2026 proposed budget reflects an **increase of \$31,548 (2.45%)**.

**Description of Significant Changes: Revenue**

Library revenues may come from a variety of sources, including:

- **Library-generated revenues**, such as fines and fees for meeting room use, material replacement, and printing/copying services
- **Investment income** earned from the Library's fund balance
- **County library aids**, which are reimbursement payments received for providing services to Waukesha County residents and residents from adjacent counties that do not support a local library
- **Grants and donations** from individuals, organizations, and foundations
- **Minimum Library Appropriation** from both the City and the Village
- **Additional municipal contributions** from the City and Village
- **Library fund balance**, used as a last resort to cover any funding gaps
- **Maintenance of Effort contributions** from both the City and the Village
- **Additional municipal contributions** from the City and Village, as needed
- **Library fund balance**, used as a last resort to cover any funding gaps

For Library-generated revenues and investment income, the proposed 2026 budget is based on actual revenues collected in 2024, the most recent complete budget year.

*Fund Balance (Decrease of \$57,211 or 100%)*

In 2025, the Library adopted a new **Fund Balance Policy** requiring an annual review to ensure the fund balance remains between 15% and 20% of the Library's operating budget. **Appendix A** includes a copy of the current fund balance analysis.

This analysis does not account for the projected use of \$57,211 from the fund balance in 2025, and it will not be clear whether more or less of these funds will be used until the 2025 budget year concludes. At present, the Library's fund balance is within the recommended range. However, if the full \$57,211 allocation is utilized, the fund balance would drop to approximately 13% of the operating budget—below the policy's minimum threshold. In light of this projection, the use of fund balance is not recommended for the 2026 budget.

*County Library Aids (Increase of \$19,805 or 17.29%)*

- **Waukesha County Aid:** We will receive a welcomed increase in Waukesha County Library Aid for 2026. This revenue is based on our 2024 circulation to Waukesha County residents who live in communities without a municipal library—also known as True Non-Residents (TNRs). The funding is generated through the Waukesha County Library Tax, which is levied on these non-librarians residents. One of the factors which have contributed to this increase is an increase in circulation by TNR residents.

- **Other County Aids:** These revenues are based on our 2024 circulation to residents of adjacent counties who also live in non-librarians communities. Under current guidelines, libraries are eligible to receive reimbursement at **70% of the calculated cost per circulation**. Requests for reimbursement have been submitted to the appropriate counties.

*Donations (Decrease of \$1,000 or 12.5%)*

- This decrease mirrors the decrease in the expenditure line for budgeted donations.

*City Contribution: MIN (Increase of \$9,699 or 1.12%)*

This is the minimum library appropriation that is required by the City to qualify their residents for exemption from the Library Count Tax. Since the City participates in a Joint Library, they are able to use the alternative calculation outlined in Wis. Stat. § 43.64(2)(c), which sets the minimum appropriation at no less than the average of the past three years.

The 2026 minimum appropriation amount, based on this calculation, is:

**Year City of Pewaukee**

2023	\$871,795
2024	\$896,676
2025	\$869,687
<b>2026</b>	<b>\$879,386</b>

*Village Contribution MIN (Increase of \$324 or .12%)*

Based on the same law and calculation described above, the 2026 minimum appropriation amounts for the Village are:

**Year** <sup>41</sup> **Village of Pewaukee**

2023 \$262,744

2024 \$262,534

2025 \$262,153

**2026 \$262,477**

*City Contribution above the MIN (Increase of \$11,080 or 100%)*

In 2025, the City did not provide funding beyond the state-required minimum. As a result, the Library's fund balance was used to close the budget gap. However, the underlying expenses still remain. The 2026 budget proposes requesting additional funding from the City to support these ongoing operational costs. **Appendix B** includes the explanation and formula used to calculate this contribution.

*Village Contribution above the MIN (Increase of \$5,977 or 100%)*

In 2025, the Village did not provide funding beyond the state-required minimum. As a result, the Library's fund balance was used to close the budget gap. However, the underlying expenses still remain. The 2026 budget proposes requesting additional funding from the Village to support these ongoing operational costs. **Appendix B** includes the explanation and formula used to calculate this contribution.

## Appendix A<sup>42</sup>

### Library Fund Balance

According to the 2024 Library Audit, the Fund Balances are as follows:

- **Restricted:** \$55,513
- **Unassigned:** \$233,130

In alignment with the Library's Fund Balance Policy, the Board reviews the Fund Balance annually upon receipt of the audit report. As part of this review, the unassigned portion of the Fund Balance is compared to the Library's current total operating budget. The policy sets a target for the unassigned fund balance to fall between **15% and 20%** of the operating budget.

For 2025, the Library's approved operating budget is **\$1,345,578**. Based on the current unassigned fund balance of **\$233,130**, the Library's unassigned reserves represent **17.33%** of the 2025 operating budget—within the targeted range.

# Appendix B

43

## Calculation of Requested Contribution Above the Minimum

The Joint Library Agreement between the Village of Pewaukee and the City of Pewaukee states:

**Section 4.3.4** – *Approved expenditures exceeding the revenue and maintenance of effort (MOE) requirements outlined in Sections 4.3.1 and 4.3.2 shall be shared by each municipality. The cost-sharing shall be based on the percentage of each municipality’s resident circulation—both physical and digital—from the year prior to the budget’s approval, as recorded by the Joint Library.*

The following outlines how each municipality's additional contribution for 2026 is calculated, using 2024 circulation data for both physical and digital materials.

### **Budget Totals Formula – 2026**

- **City Minimum Appropriation (MIN):** \$879,386
- **Village Minimum Appropriation (MIN):** \$262,477
- **General Revenues:** \$178,544
- **Total Revenues:** \$1,320,407
- **Total Expenditures:** \$1,337,464
- **Request Above MIN:** \$17,057

### **Circulation from the Pewaukee Library (Including Digital Circulation)**

*Based on 2024 circulation data, applied to the 2026 budget year.*

	<b>City</b>	<b>Village</b>
Physical Circulation	114,300	63,868
Digital Circulation	30,823	14,411
<b>Total Circulation</b>	<b>145,123</b>	<b>78,279</b>
<b>Percent of Total</b>	<b>65%</b>	<b>35%</b>

**Total Systemwide Circulation:** 223,402

### **Additional Contributions Based on Circulation Percentages**

- **Additional City Contribution:** \$11,080.31
- **Total City Contribution:** \$890,466
- **Additional Village Contribution:** \$5,976.69
- **Total Village Contribution:** \$268,454

**Pewaukee Public Library 2026 Proposed Budget  
August 2025**

<b>EXPENDITURES</b>	<b>Budget 2024</b>	<b>Actual 2024</b>	<b>Actual 2024</b>	<b>June 30, 2025 Actual</b>	<b>Budget 2025</b>	<b>Budget 2026</b>	<b>Actual +/-</b>	<b>% Change</b>
<b>110 Library Salaries</b>	<b>668,000</b>	<b>661,429</b>	<b>-6,571</b>	<b>304,549</b>	<b>688,000</b>	<b>708,590</b>	<b>20,590</b>	<b>2.99%</b>
<b>130 Benefits</b>	<b>213,710</b>	<b>209,182</b>	<b>-4,528</b>	<b>110,982</b>	<b>223,435</b>	<b>220,186</b>	<b>-3,249</b>	<b>-1.45%</b>
Social Security (6.2%)	41,416	39,796	-1,620	18,064	42,650	43,932	1,282	3.01%
Medicare (1.45%)	9,686	9,307	-379	4,225	9,975	10,275	300	3.01%
Retirement (WRS 7.2%)	37,691	36,897	-794	16,341	36,502	38,242	1,740	4.77%
Dental	2,045	1,868	-177	843	1,865	1,571	-294	-15.79%
Disability	4,000	3,730	-270	1,855	3,964	3,621	-343	-8.65%
Health	117,660	116,574	-1,086	69,034	127,511	121,770	-5,741	-4.50%
Life Insurance	1,212	1,010	-202	466	968	775	-193	-19.94%
<b>Materials Budget</b>	<b>125,462</b>	<b>126,885</b>	<b>1,423</b>	<b>51,037</b>	<b>126,307</b>	<b>128,737</b>	<b>2,430</b>	<b>1.92%</b>
140 Subscriptions	7,000	6,875	-125	2,053	7,000	7,000	0	0.00%
141 Print Materials	80,500	76,977	-3,523	25,891	80,500	80,500	0	0.00%
142 Non-Print Materials	14,000	13,029	-971	6,918	14,700	14,700	0	0.00%
312 Digital Materials	23,962	30,005	4,795	16,175	24,107	26,537	2,430	10.08%
<b>143 Technology</b>	<b>44,628</b>	<b>45,811</b>	<b>1,183</b>	<b>33,618</b>	<b>45,548</b>	<b>45,526</b>	<b>-22</b>	<b>-0.05%</b>
CAFÉ - ILS System	24,176	24,176	0	25,366	25,366	25,252	-114	-0.45%
Computer								
Equipment/Installation	9,000	11,511	2,511	1,827	9,000	9,000	0	0.00%
Taylor Computing - Managed Services	5,800	3,774	-2,026	2,080	4,244	4,160	-84	-1.98%
Software Licenses	2,675	1,936	-739	1,427	3,280	2,700	-580	-17.68%
Envisionware Software & Maintenance	1,777	3,214	1,437	2,317	2,458	3,214	756	30.76%
T-1 Line: Wisnet	1,200	1,200	0	600	1,200	1,200	0	0.00%
<b>144 Mileage, Supplies, Other Expenditures</b>	<b>19,580</b>	<b>19,452</b>	<b>-128</b>	<b>5,766</b>	<b>14,045</b>	<b>13,600</b>	<b>-445</b>	<b>-3.17%</b>
Copier Services: James Imaging Contract	6,680	5,352	-1,328	0	0	0	0	#DIV/0!
Rhyme Copier Maintenance Contract	0	1,063	1,063	960	1,400	1,400	0	0.00%
Marketing	900	850	-50	0	0	0	0	#DIV/0!
Postage/Shipping/Freight	1,500	184	-1,316	194	1,145	200	-945	-82.53%
Office Supplies	5,000	3,499	-1,501	1,762	4,000	3,500	-500	-12.50%
RFID Tags	1,500	3,038	1,538	936	1,500	3,000	1,500	100.00%
Processing/Repair Supplie	4,000	5,466	1,466	1,913	6,000	5,500	-500	-8.33%
<b>146 Staff Development</b>	<b>3,750</b>	<b>3,560</b>	<b>-190</b>	<b>1,473</b>	<b>3,000</b>	<b>3,000</b>	<b>0</b>	<b>0.00%</b>
Conference Attendance	2,000	1,218	-782	45	1,500	1,500	0	0.00%
Professional Association Memberships	1,000	1,151	151	400	750	750	0	0.00%
Staff Development Days	0	330	330	880	350	350	0	0.00%
New Hire	250	320	70	47	150	150	0	0.00%
Mileage	500	541	41	100	250	250	0	0.00%

**Pewaukee Public Library 2026 Proposed Budget  
August 2025**

<i><b>EXPENDITURES</b></i>	<i><b>Budget</b></i>	<i><b>Actual</b></i>	<i><b>Actual</b></i>	<i><b>June 30,</b></i>	<i><b>Budget</b></i>	<i><b>Budget</b></i>	<i><b>Actual</b></i>	<i><b>%</b></i>
	<i><b>2024</b></i>	<i><b>2024</b></i>	<i><b>2024</b></i>	<i><b>2025</b></i>	<i><b>2025</b></i>	<i><b>2026</b></i>	<i><b>+/-</b></i>	<i><b>Change</b></i>
				<i><b>Actual</b></i>				
<b>150 Professional Services</b>	<b>45,936</b>	<b>47,015</b>	<b>1,079</b>	<b>8,944</b>	<b>45,936</b>	<b>47,015</b>	<b>1,079</b>	<b>2.35%</b>
Auditing Services	6,350	6,673	323	5,401	6,350	6,673	323	5.09%
Fiscal Agent Services	19,086	19,086	0	3,543	19,086	19,086	0	0.00%
Insurance: Liability	6,800	6,006	-794	0	6,800	6,006	-794	-11.68%
Insurance: Property	12,700	14,397	1,697	0	12,700	14,397	1,697	13.36%
Insurance: Worker's Comp	1,000	853	-147	0	1,000	853	-147	-14.70%
<b>160 Library Annual Municipal Fees</b>	<b>7,776</b>	<b>3,106</b>	<b>-4,670</b>	<b>0</b>	<b>3,782</b>	<b>2,200</b>	<b>-1,582</b>	<b>-41.83%</b>
Utility - Water, Sewer Stormwater, Fire Prot.								
Publ Fire Prot	2,000	1,218	-782	1,100	2,095	2,200	105	5.01%
Utility - Transportation	3,776	1,889	-1,887	0	0	0	0	#DIV/0!
Fire and EMS	2,000	0	-2,000	0	1,687	0	-1,687	-100.00%
<b>310 Building Maintenance</b>	<b>89,700</b>	<b>115,766</b>	<b>26,066</b>	<b>41,512</b>	<b>93,332</b>	<b>92,813</b>	<b>-519</b>	<b>-0.56%</b>
Carpet/Window Cleaning	3,400	0	-3,400	0	3,400	3,400	0	0.00%
Cleaning Services (Contract)	32,730	32,808	78	16,704	33,385	34,076	691	2.07%
Cleaning/Building Supplies	4,000	3,741	-259	466	4,000	4,000	0	0.00%
Elevator Inspections/Permits/Maintenance	1,800	13,836	12,036	1,702	1,977	1,640	-337	-17.05%
Fire: Inspections & Permits & Maintenance	1900	1,775	-125	5,734	4,561	1,775	-2,786	-61.08%
Fire Monitoring	1400	1,700	300	1,570	1,400	1,700	300	21.43%
General: Maintenance & Repair & Speciality								
Cleaning	12,000	25,647	13,647	3,836	12,000	12,000	0	0.00%
HVAC Maintenance	6,500	4,700	-1,800	469	7,756	4,700	-3,056	-39.40%
Lawn Care	15,790	20,561	4,771	5,940	17,678	18,523	845	4.78%
Snow Plowing	10,180	10,999	819	5,091	7,175	10,999	3,824	53.30%
<b>311 Utilities</b>	<b>55,013</b>	<b>53,034</b>	<b>-1,979</b>	<b>21,638</b>	<b>52,930</b>	<b>53,034</b>	<b>104</b>	<b>0.20%</b>
Electric	40,000	39,843	-157	14,262	39,279	39,843	564	1.44%
Gas	8,600	6,769	-1,831	4,358	6,681	6,769	88	1.32%
Telephone	6,413	6,422	9	3,018	6,970	6,422	-548	-7.86%
<b>313 Programs</b>	<b>5,250</b>	<b>5,132</b>	<b>-118</b>	<b>2,010</b>	<b>5,000</b>	<b>5,000</b>	<b>0</b>	<b>0.00%</b>
Programming - Adult	2,250	2,340	90	400	2,000	2,000	0	0.00%
Programming - Children's	3,000	2,077	-923	1,243	2,500	2,250	-250	-10.00%
Programming - Young Adult	0	715	715	366	500	750	250	50.00%
<b>400 Legal</b>	<b>4,000</b>	<b>6,309</b>	<b>2,309</b>	<b>2,653</b>	<b>4,000</b>	<b>4,000</b>	<b>0</b>	<b>0.00%</b>

**Pewaukee Public Library 2026 Proposed Budget  
August 2025**

<b>EXPENDITURES</b>	<b>Budget</b>	<b>Actual</b>	<b>Actual</b>	<b>June 30, 2025</b>	<b>Budget</b>	<b>Budget</b>	<b>Actual</b>	<b>%</b>
	<b>2024</b>	<b>2024</b>	<b>2024</b>	<b>Actual</b>	<b>2025</b>	<b>2026</b>	<b>+/-</b>	<b>Change</b>
<b>450 Grants</b>	<b>9,038</b>	<b>10,588</b>	<b>1,550</b>	<b>9,063</b>	<b>6,763</b>	<b>6,763</b>	<b>0</b>	<b>0.00%</b>
Bridges Grants (E-Materials)	6,038	6,038	0	3,263	3,263	3,263	0	0.00%
Bridges Non Competitive Grant (Non-materials)	3,000	3,000	0	0	3,500	3,500	0	0.00%
Bridges Competative Grant	0	0		5,000	0	0	0	#DIV/0!
LSTA SEWI Grant	0	1,500	1,500	0	0	0	0	#DIV/0!
Delta Grant	0	0	0	300	0	0	0	#DIV/0!
Greater MKE Foundation	0	50	50	500	0	0	0	#DIV/0!
<b>500 Donations</b>	<b>6,500</b>	<b>17,119</b>	<b>10,619</b>	<b>7,423</b>	<b>8,000</b>	<b>7,000</b>	<b>-1,000</b>	<b>-12.50%</b>
Friends : Explore Passes/Library of Things	6,500	5,499	-1,001	2,396	8,000	7,000	-1,000	-12.50%
Donations: Various	0	11,620	11,620	5,027	0	0		
<b>000 Library Outlay (Fund Balance)</b>	<b>20,200</b>	<b>68,646</b>	<b>48,446</b>	<b>27,179</b>	<b>25,000</b>	<b>0</b>	<b>-25,000</b>	<b>-100.00%</b>
Purchase 2 new copy machines	10,000	8,374	-1,626	0	0	0	0	#DIV/0!
Security Gates	10,200	11,291	1,091	0	0	0	0	#DIV/0!
LED Light Upgrade		4,800	4,800	7,244	10,000	0	-10,000	-100.00%
Security Camera Replacement		44,181	44,181	19,935	15,000	0	-15,000	-100.00%
<b>TOTAL EXPENDITURES</b>	<b>1,318,543</b>	<b>1,393,034</b>	<b>74,491</b>	<b>627,846</b>	<b>1,345,078</b>	<b>1,337,464</b>	<b>-7,614</b>	<b>-0.57%</b>

**Pewaukee Public Library 2026 Proposed Budget  
August 2025**

<b>REVENUES</b>	<b>Budget 2024</b>	<b>Actual 2024</b>	<b>June 30,</b>		<b>Budget 2025</b>	<b>Budget 2026</b>	<b>Actual +/-</b>	<b>% Change</b>
			<b>Actual 2024</b>	<b>2025 Actual</b>				
<b>43790 County Lib Aids</b>	<b>118,774</b>	<b>118,324</b>	<b>-450</b>	<b>59,382</b>	<b>114,563</b>	<b>134,368</b>	<b>19,805</b>	<b>17.29%</b>
<b>Waukesha County</b>	114,627	114,627	0	55,175	110,349	129,179	18,830	17.06%
<b>Prairie Lakes</b>	897	446	-451	7	13	268	255	1961.54%
<b>Jefferson Co.</b>	2,250	2,250	0	3,235	3,235	3,401	166	5.13%
<b>Dodge Co.</b>	488	489	1	245	245	383	138	56.32%
<b>Ozaukee Co.</b>	0	0	0	30	30	0	-30	-100.00%
<b>Washington Co.</b>	512	512	0	691	691	1,137	446	64.54%
<b>46710 Library Fines</b>	<b>7,609</b>	<b>8,054</b>	<b>445</b>	<b>4,246</b>	<b>8,681</b>	<b>8,054</b>	<b>-627</b>	<b>-7.22%</b>
<b>48110 Interest Income</b>	<b>338</b>	<b>6,215</b>	<b>5,877</b>	<b>3,393</b>	<b>9,769</b>	<b>6,214</b>	<b>-3,555</b>	<b>-36.39%</b>
<b>7-Month CD</b>		1,316		0	2,887	1,316	-1,571	-54.42%
<b>15-Month CD</b>		1,187		0	5,680	1,187	-4,493	-79.10%
<b>North Shore Interest</b>		1,149		324	0	1,148	1,148	#DIV/0!
<b>LGIP Interest</b>		2,563		3,070	1,202	2,563	1,361	113.23%
<b>48500-000 Donations</b>	<b>6,500</b>	<b>21,812</b>	<b>15,312</b>	<b>17,700</b>	<b>8,000</b>	<b>7,000</b>	<b>-1,000</b>	<b>-12.50%</b>
<b>48500-100 Misc. Revenues</b>	<b>6,500</b>	<b>15,645</b>	<b>9,145</b>	<b>5,424</b>	<b>8,251</b>	<b>15,645</b>	<b>7,394</b>	<b>89.61%</b>
<b>48500-200 Grants</b>	<b>9,038</b>	<b>11,720</b>	<b>2,682</b>	<b>3,563</b>	<b>7,263</b>	<b>7,263</b>	<b>0</b>	<b>0.00%</b>
Bridges - Hoopla Grant	6,038	6,038	0	3,263	3,263	3,263	0	0.00%
Bridges - Innovation Grants	3,000	3,000	0	0	3,500	3,500	0	0.00%
Delta Kappa Gamma Bridges - Adult Program Grant		202		300				
LSTA SEWI Grant		400		0	500	500		
		2,081						
<b>48440-000 Insurance Recoveries</b>	<b>0</b>	<b>48,736</b>	<b>48,736</b>	<b>0</b>	<b>0</b>	<b>0</b>	<b>0</b>	<b>#DIV/0!</b>
<b>49300-000 Fund Balance Applied</b>	<b>20,200</b>	<b>3,319</b>	<b>-16,881</b>	<b>0</b>	<b>57,211</b>	<b>0</b>	<b>-57,211</b>	<b>-100.00%</b>
<b>Revenue Sub Total</b>	<b>148,759</b>	<b>230,505</b>	<b>81,746</b>	<b>93,709</b>	<b>213,738</b>	<b>178,544</b>	<b>-35,194</b>	<b>-16.47%</b>
<b>Total Contribution Subtotal</b>	<b>1,169,784</b>	<b>1,162,529</b>	<b>-7,255</b>	<b>534,138</b>	<b>1,131,340</b>	<b>1,158,920</b>	<b>27,579</b>	<b>2.44%</b>
<b>49000-000 City Contribution MIN.</b>			0	434,934	869,687	879,386	9,699	1.12%
<b>49000-000 City Above the MIN.</b>			0	0	0	11,080	11,080	100.00%
<b>Total City Contribution</b>	<b>896,675</b>	<b>896,675</b>	<b>0</b>	<b>434,934</b>	<b>869,687</b>	<b>890,466</b>	<b>20,779</b>	<b>2.39%</b>
<b>49001-000 Village Contribution MIN.</b>			0	131,076	262,153	262,477	324	0.12%
<b>49001-000 Village Above the MIN</b>			0	0	0	5,977	5,977	100.00%
<b>Total Village Contribution</b>	<b>262,534</b>	<b>262,534</b>	<b>0</b>	<b>131,076</b>	<b>262,153</b>	<b>268,454</b>	<b>6,301</b>	<b>2.40%</b>
<b>SUB TOTAL</b>	<b>1,307,968</b>	<b>1,389,714</b>	<b>81,746</b>	<b>659,719</b>	<b>1,345,578</b>	<b>1,337,464</b>	<b>-8,114</b>	<b>-0.60%</b>

## Pewaukee Public Library 2026 Budget - 5 YR Capital Projects Plan DRAFT 8.2025

Interior/Exterior	ITEM DESCRIPTION	TOTAL COST TO REPLACE	Quote Provided by	Quote Year	2026 BUDGET	2027 BUDGET	2028 BUDGET	2029 BUDGET	2020 BUDGET
Exterior	Parking lot - blacktop and curb replacement	\$126,292.00	PLM Paving and Concrete	2023			X		
Exterior	Roof - Flat	\$130,000.00	Garland	2025	X				
Interior	HVAC : Control System (Front End)	\$77,974.00	Grunau	2024		X			
	<b>Total</b>	\$334,266.00							

# Pewaukee Public Library

210 Main Street • Pewaukee, WI 53072

## Roof Inspections & Budgets



Partners for the life of your building.®

# The Garland Company

## Building Envelope Solutions



- A Full Service, ISO Certified, Roof Asset Management Company, Established in 1895.
- Manufactures a Full Line of High-Performance Products:
  - ✓ Modified Bitumen Roof System
  - ✓ Single Ply Hybrid Roof Systems
  - ✓ Standing Seam and Flat Seam Metal Roofing
  - ✓ Fluid Applied Membranes
  - ✓ Full Line of Maintenance Products
  - ✓ Green Roofing and Sustainable Design
- Deep Product Selection Backed by Ongoing R&D
- Sustainable and Green Roofing Options
- ESOP Company
- Lowest Warranty Adjustment Rating in the Industry



# Chain of Liability

## Commodity Manufacturer



BUILDING/ROOFING  
CONSULTANT

CONTRACTORS

SUPPLY HOUSE

MANUFACTURER

- High Soft Costs
- No direct involvement from Manufacturer (Warranty holder)
- Minimized ability to affect or control quality of work or product

## Full-Service Manufacturer



- Analysis and Design
- Inspections
- Project Management
- Preventative Maintenance
- Design

CONTRACTORS

- Minimal Soft Costs
- Direct Manufacturer Involvement
  - Proper product applications
  - Focused on long term success (Warranty holder)
- One contact to oversee, inspect, and update throughout entire process
- Facilitate Bid process and cut out administrative burden for customer
- True Apples-to-Apples bid comparison
- Ability to compare/evaluate all roofing system types



# ***PUBLIC LIBRARY***





Shingle Roof with Mineral Loss and Areas of Missing Shingle

Past Leak Areas



Areas of Tenting  
along Flashings





Number of Repairs  
Needed to Top of  
Elevator





Large wrinkles and areas of unadhered roof membrane, due to poor installation quality

# *Budgets*

# Pewaukee Public Library

210 Main Street • Pewaukee, WI 53072

## Public Library Inspection and Budgets

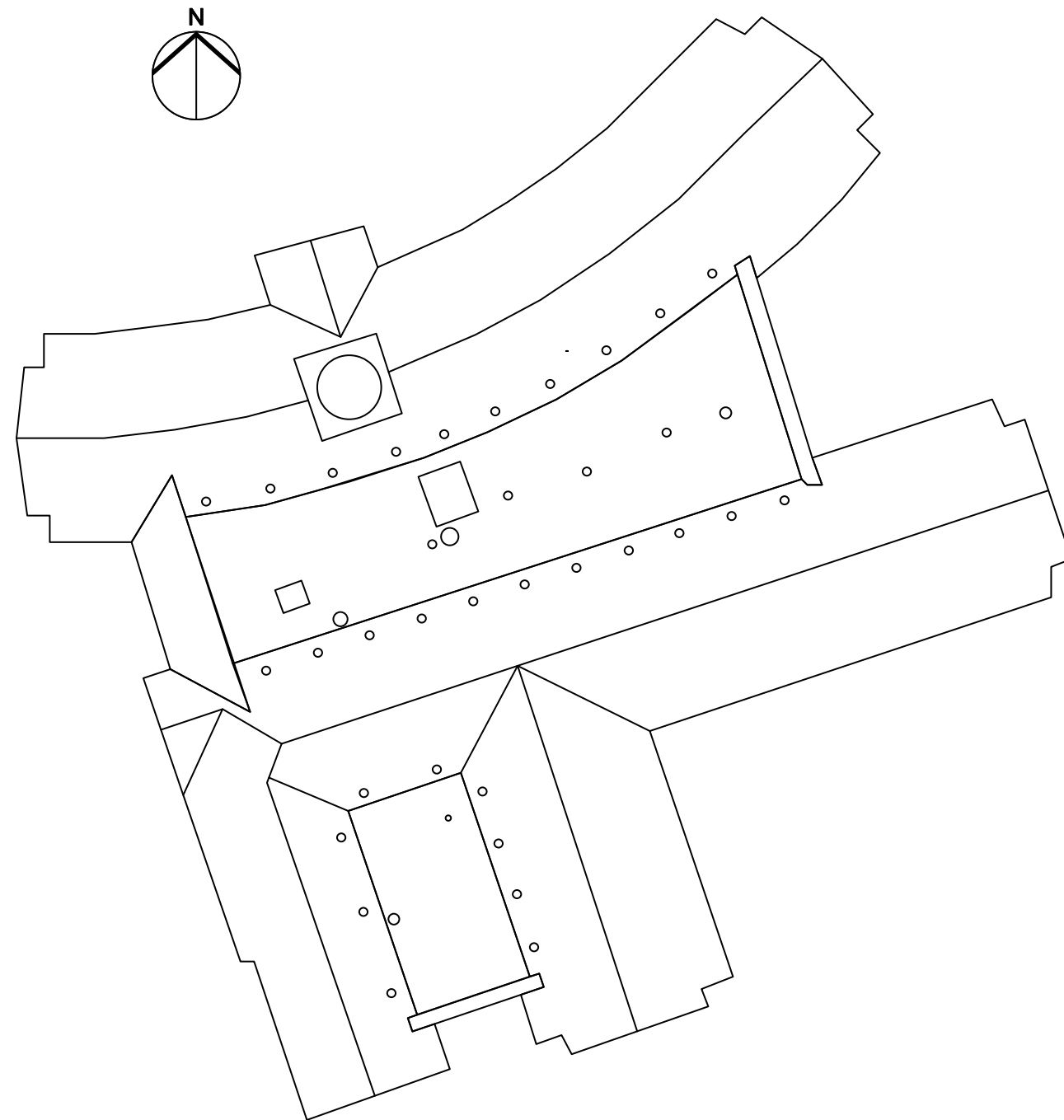
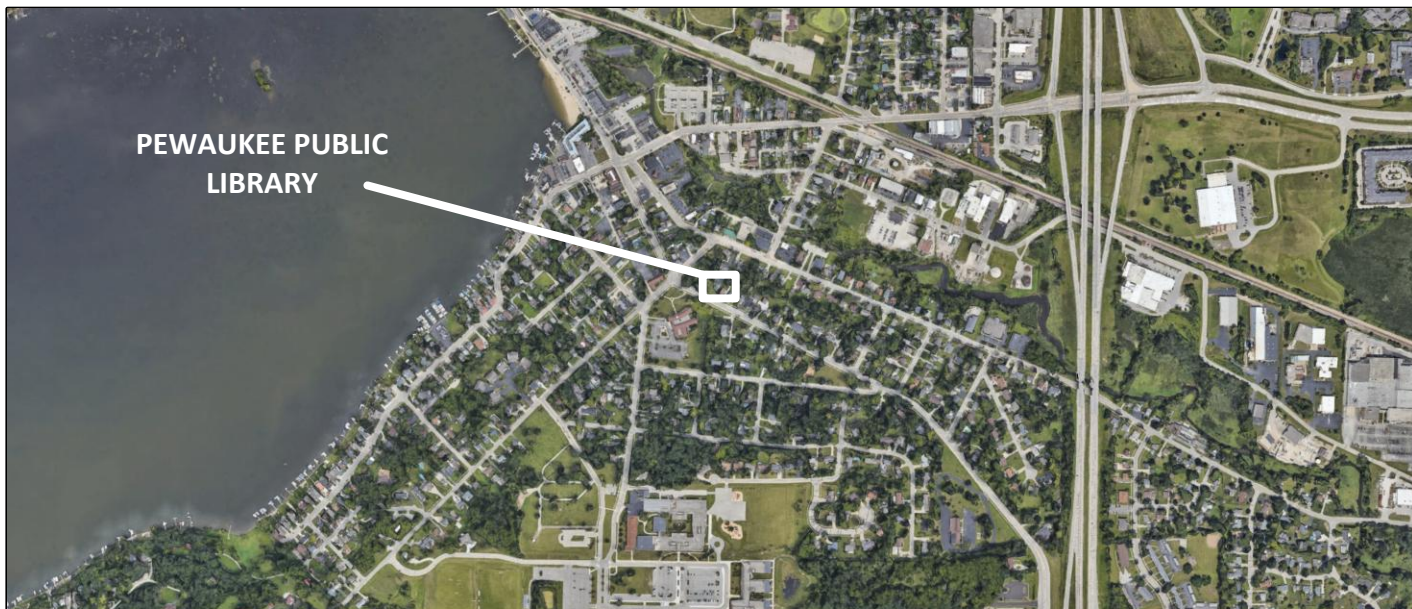

The Garland Company  
 3800 E. 91<sup>st</sup> Street  
 Cleveland, OH 44105

THE INFORMATION CONTAINED HEREIN IS OF A PROPRIETARY NATURE AND IS SUBMITTED IN CONFIDENCE FOR USE BY THE CLIENTS APPROVED BY THE ORIGINATOR OF THIS DOCUMENT - ONLY. THE USE OF THESE DOCUMENTS FOR ANY OTHER PROJECTS, PURPOSE, LOCATION, PUBLICATION, REPRODUCTION OR DISTRIBUTION IN WHOLE OR PART, BY ANY INDIVIDUAL OR ORGANIZATION WITHOUT WRITTEN PERMISSION THE ORIGINATING COMPANY IS PROHIBITED. THE INFORMATION HEREIN REMAINS THE PROPERTY AND ITS USE OR DISCLOSURE TO OTHERS IS PROHIBITED FOR ANY USE NOT AUTHORIZED BY THE ORIGINATING COMPANY.

ISSUED:

8.14.2025

City of Pewaukee – Public Library  
 210 Main Street, Pewaukee, WI 53072

SHEET TITLE:

COVER PAGE

SHEET NO.

A-1



# Public Library – Facility Roof Budgets



The Garland Company  
3800 E. 91<sup>st</sup> Street  
Cleveland, OH 44105

THE INFORMATION CONTAINED HEREIN IS OF A PROPRIETARY NATURE AND IS SUBMITTED IN CONFIDENCE FOR USE BY THE CLIENTS APPROVED BY THE ORIGINATOR OF THIS DOCUMENT - ONLY. THE USE OF THESE DOCUMENTS FOR ANY OTHER PROJECTS, PURPOSE, LOCATION, PUBLICATION, REPRODUCTION OR DISTRIBUTION IN WHOLE OR PART, BY ANY INDIVIDUAL OR ORGANIZATION WITHOUT WRITTEN PERMISSION THE ORIGINATING COMPANY IS PROHIBITED. THE INFORMATION HEREIN REMAINS THE PROPERTY AND ITS USE OR DISCLOSURE TO OTHERS IS PROHIBITED FOR ANY USE NOT AUTHORIZED BY THE ORIGINATING COMPANY.

ISSUED:  
**8.14.2025**

City of Pewaukee – Public Library  
210 Main Street, Pewaukee, WI 53072

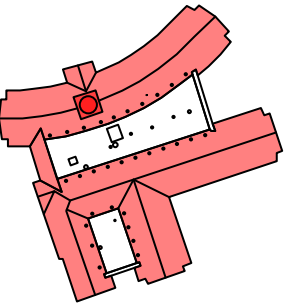
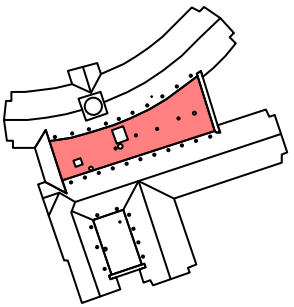
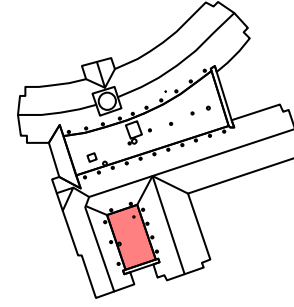
	<h1>Public Library – Facility Roof Budgets</h1>				
	Facility Roof Description	Square Footage	Roof Type	Estimated Roofing Budget Year	Roof System Warranty Budget
	Main Shingle Roof	17,000	Asphaltic Shingle	2035	<u>Asphalt Shingle (30 YR)</u> \$220,000
	Upper Flat Roof	3,500	Ballasted EPDM	2026	<u>MODIFIED BITUMEN (30 YR)</u> \$130,000
	Lower Flat Roof	900	TPO	2035	<u>MODIFIED BITUMEN (30 YR)</u> \$35,000

SHEET TITLE:  
**BUDGETS**

SHEET NO.  
**A-2**

# *Example Roof Photos*

# MINERAL SURFACE MODIFIED BITUMEN CITY OF PORT WASHINGTON



# FLOOD & GRAVEL SURFACE MODIFIED BITUMEN CITY OF NEW BERLIN



# CURVED STANDING SEAM METAL ROOF CITY OF WAUWATOSA







## RHETT SURMAN

I am the Territory Manager for the Milwaukee, WI area, helping local facilities repair, replace, and evaluate their roofing and waterproofing needs. As an expert in the waterproofing industry, I have helped execute the projects listed here, covering a wide range of tasks, which including: visual inspection, core cuts & roof assembly testing, water tests, destructive testing, creating Long Term Facility Plans & reports, project budgeting, Financial Life-Cycle Costing Analysis, performing Facility Condition Assessments, project Specification & Design, Repair - Maintenance Scope of Work documents, Wind Up-Lift Calculations, Structural Engineer reviews, FM approval submittals, Bidding services, Project Bid Documents (Bid Tabulations & Letter of Recommendation), Board Presentations, Project Management (multiple trades), Project Inspections, Punch List & Final Project walk/Overviews, and Project Close Outs.



LET'S CONNECT

## PUBLIC LIBRARY EXPERIENCE

### **CITY OF WAUKESHA • PUBLIC LIBRARY • ASPHALTIC MOD BIT ROOF & SHINGLE ROOF**

Installation of 3 Ply Hot Asphalt Applied Asphaltic Roof with Flood and Gravel Surface, Asphaltic Shingle Roof, Translucent Panels, and Metal Wall Cladding

### **CITY OF WAUWATOSA • PUBLIC LIBRARY • ADHERED EPDM ROOF, KALWALL TRANSLUCENT PANELS, MODIFIED BITUMEN REPAIRS & SHINGLE ROOF**

Installation of 60MIL Adhered EPDM Roof,, Asphaltic Shingle Roof, Translucent Panels, and Metal Wall Cladding

### **CITY OF PORT WASHINGTON • WJ NEIDERKORN LIBRARY • ASPHALTIC BUILT-UP ROOF & SHINGLE ROOF**

Installation of 4 Ply Torch Applied Asphaltic Roof with Aluminized Surface Coating

### **CITY OF SOUTH MILWAUKEE • PUBLIC LIBRARY • ASPHALTIC MOD BIT ROOF**

Installation of 3 Ply Hot Asphalt Applied Asphaltic Roof with Mineral Surface and Aluminized Coating

### **CITY OF KENOSHA • UPTOWN LIBRARY • ASPHALTIC MOD BIT ROOF & SHINGLE ROOF**

Installation of 2 Ply Self Adhered Asphaltic Roof with Mineral Surface and Asphaltic Shingle Roof

### **VILLAGE OF MUKWONGAO • PUBLIC LIBRARY • FACILITY PLANNING**

Inspection and Review of Facility roofs and exterior waterproofing, capital budgeting, and installation of roof repairs.

### **VILLAGE OF SUSSEX • PUBLIC LIBRARY • FACILITY PLANNING**

Inspection and Review of Facility roofs and exterior waterproofing, capital budgeting, and installation of roof repairs.



**CITY OF OAK CREEK • PUBLIC LIBRARY • ADHERED EPDM**

Installation of Adhered EPDM roof repairs and maintenance, throughout facility roof

**CITY OF GREENFIELD • PUBLIC LIBRARY • ASPHALTIC MOD BIT ROOF**

Installation of 3 Ply Hot Asphalt Applied Asphaltic Roof with Flood and Gravell Surface

**VILLAGE OF GRAFTON • PUBLIC LIBRARY • ASPHALTIC MOD BIT ROOF**

Installation of 2 Ply Hot Asphalt Applied Asphaltic Roof with Mineral Surface



City of Waukesha Public Library

# Developing Essential Library Policies

Policies guide the daily operation of the library and the decision-making of the library director and staff. Essentially, policies provide the framework for library operations and services. Carefully developed policies can help ensure high-quality library service that provides for community needs, wise use of library resources, and fair treatment of library staff and library users.

Library boards should approve policies to cover many issues, including the services offered by the library (such as the hours the library is open to the public), circulation of materials, selection of books and other resources, confidentiality of patron records, and use of electronic resources. The library personnel policy (see [Trustee Essential #7: The Library Board and Library Personnel](#)) and the board bylaws (see [Trustee Essential #3: Bylaws—Organizing the Board for Effective Action](#)) are two essential statements of policy relating to library and library board internal operations.

Wisconsin Statutes authorize the library board to establish both “external policies” (policies that determine how the library serves the public) and “internal policies” (policies that govern library board operations and library management). Wisconsin Statutes Section 43.52(2) provides that “[e]very public library shall be . . . subject to such reasonable regulations as the library board prescribes in order to render its use most beneficial to the greatest number. The library board may exclude from the use of the public library all persons who willfully violate such regulations.” Additional broad authority is granted by Section 43.58(4): “. . . [T]he library board shall supervise the administration of the public library and shall appoint a librarian . . . and prescribe [library employee] duties and compensation.”

## Policy Development Steps

The following basic steps provide for careful development and review of library policies:

1. Director, with staff (and maybe public) input, develops recommended policies.
2. Board discusses, revises (if necessary), and approves policies.
3. Director makes sure staff and public are aware of policies.
4. Board reviews policies on a regular cycle so all policies are reviewed at least every three years (perhaps one or two policies could be reviewed per meeting until all of the policies have been reviewed, and revised if necessary).

The library board must approve all policies in properly noticed public meetings (see [Trustee Essential #14: The Library Board and the Open Meetings Law](#) for details).

# 10

## In This Trustee Essential

- Who is responsible for developing and approving library policies?
- How do you develop good (and legal) policies?
- Who carries out policies?

In consideration of policy matters, it is important that you give adequate time and attention to the many complex issues that may be involved. All library policies should promote the best interests of the community and be consistent with the library's mission and strategic plan. You should be satisfied that a policy is legal, clear, and reasonable, and that all ramifications (including the effects on the public image of the library) are understood.

After a new policy is established, it is important that the policy be clearly documented and available to staff and public. It is helpful for a library to gather all library policies into a policy manual available to all staff and readily available to all library users. Many libraries are now posting their policies on their websites (see <http://dpi.wi.gov/pld/boards-directors/policy-resources> for examples) to help make the public more aware of the library's services and policies.

Although disagreements during the development of policies are natural, each board member should support staff in implementation of policies once they are established. Challenges to policies are most common on the topics of material selection and public Internet access (see *Trustee Essential #23: Dealing with Challenges to Materials or Policies*).

## Legally Defensible Policies

It is important for policies to be legal. Illegal policies can open the municipality to liability. (See *Trustee Essential #25: Liability Issues*, for more information.) Below are four tests of a legally defensible policy:

**Test #1: Policies must comply with current statutes and case law.** For example:

- A library policy charging patrons for use of computers in the library would be contrary to Wisconsin Statutes Section 43.52(2), which requires that public library services be provided free of charge.
- A policy that says the library's public meeting room cannot be used for religious purposes would be unconstitutional under a Wisconsin federal district court decision.

**Test #2: Policies must be reasonable** (and all penalties must be reasonable). For example:

- A library policy that says, "All talking in the library is prohibited, and anyone who talks in the library will permanently lose library use privileges," is clearly an unreasonable rule with an unreasonably harsh penalty.

**Test #3: Policies must be clear** (not ambiguous or vague). For example:

- A policy that says, "Library use privileges will be revoked if a patron has too many overdue books," is too vague to be fairly administered.

**Test #4: Policies must be applied without discrimination.** For example:

- If a library charges fines, it cannot give preferential treatment to some individual patrons. For example, if the library sometimes waives fines, that waiver must be available to all patrons on an equal basis—not just to friends of library staff or to politically important people.

Many libraries find that it is helpful when developing or revising policies to review the policies of other libraries. Many examples of Wisconsin public library policies and other resources are available from the [Wisconsin Public Library Policy Resources](#) page.

## Policies vs. Procedures

In addition to a policy manual, many libraries find it helpful to write up procedure manuals, especially for covering complex activities like the selection, ordering, and processing of new materials. Procedure manuals outline the steps necessary to accomplish various tasks and therefore are especially valuable to new staff.

Procedures must conform to the policies approved by the library board. While it is true that the library board is responsible for the entire administration of the library, your library will operate most effectively if the board delegates responsibility for the development of procedures and the day-to-day supervision of library operations to the library director. A properly trained library director is well equipped to handle this responsibility. “Micro-management” of library operations by the board is, in almost all cases, an unnecessary use of the board’s time and a practice that can undermine the authority of the library director. (See [Trustee Essential #6: Evaluating the Director](#) for recommended procedures for handling any concerns about the director’s performance.)

## Discussion Questions

1. What steps can be taken to help a library develop good policies?
2. What would be an example of a “bad” library policy, and why would it be bad?
3. What should a library trustee do if he/she disagrees with a library policy?
4. Who is responsible for carrying out library policies?

## Sources of Additional Information

- [Wisconsin Trustee Training Module #2: Development of Essential Policies for Public Libraries](#)
- Your library system staff (See [Trustee Tool B: Library System Map and Contact Information](#).)
- Your municipal or county attorney
- [Wisconsin Public Library Policy Resources](#)