

Original 2005-2006 Controls
Submittal & O&M

ASIC
ASI Controls

DATE: APRIL 1, 2005

PROJECT: PEWAUKEE PUBLIC LIBRARY

PREPARED FOR: HARWOOD ENGINEERING
7420 WEST STATE ST.
MILWAUKEE, WI 53210
PHONE 414-475-5554
FAX 414-475-5698

J & H HEATING IS PLEASED TO SUBMIT AUTOMATED TEMPERATURE
CONTROL SYSTEM FOR YOUR REVIEW

1. ASIC/2 CONFIGURABLE SYSTEM CONTROLLER
2. SENSORS AND SUPPORTING DEVICES
3. SEQUENCE OF OPERATIONS
4. CONTROL DIAGRAM, POINTS LIST
5. AS BUILT LOGIC
6. VALVE SCHEDULE

CHRIS WITTIG
J & H HEATING, INC.
1220 MINERAL SPRINGS DRIVE
PORT WASHINGTON, WI 53074
PHONE 262-284-5589
FAX 262-284-3389

Tab 1



ASI Controls

Configuration Software

ASI Expert Features

- Common User Interface
- Easy to understand screens
- Visual Configuration
- Modem Dialing Support
- ASI Peer-to-Peer or Polling Network access
- Supports all ASI product families including ASIC/1, ASIC/2, SINC
- Integration with ASI Monitor
- No programming language needed

ASI Expert Software is designed to provide a single environment to allow ASI Controls users a simple-to-use way of configuring control systems, including configuring controllers, setting-up and testing networks, debugging and commissioning systems, documenting projects and maintaining them over time.

The current version of ASI Expert is capable of configuring and maintaining the following controllers:

ASIC/2-7040, ASIC/2-8040, ASIC/1-8055, ASIC/1-8255, ASIC/1-8355, ASIC/1-8755, ASIC/1-8655
SINC/2-2000 and SINC/3-3000.

ASI Expert software allows Visual programming of ASI configurable controllers. Instances can be added to the drawing on-line or off-line so that the sequence of operation can be designed, configured, and documented in one operation. When configuring off-line ASI Expert allocates additional object instances as needed. When configuring on-line ASI Expert displays real-time data from the controller so that the sequence can be tested as it is developed.

Each drawing page represents a Function Group that graphically shows each instance and their interconnections. A Function Group is a collection of instances of ASIC/2 objects that have been configured to meet a specific requirement for control. Examples of function groups,

include Economizer Sequence, Time of Day Scheduling, Heating and Cooling Calculation, Compressor Staging with minimum on and off times, etc. Function Groups may be saved and re-used in other configurations.

The software may be used to access controllers across local or wide area networks so that system start-up and maintenance may take place from a single location. ASI Expert can connect to an ASI network through a COM port or over a modem. It can also connect through the ASI OPC server and an ASI Etherlink using TCP/IP over a LAN, WAN, or internet connection.

With ASI Expert you can get online with controllers, work with them, test them and save configurations to hard disk. The configurations can then be downloaded to the controllers to be sent to the job site.

The project view gives an overview of all controllers on a project. By clicking on the project tree one can immediately establish communications with the controllers.

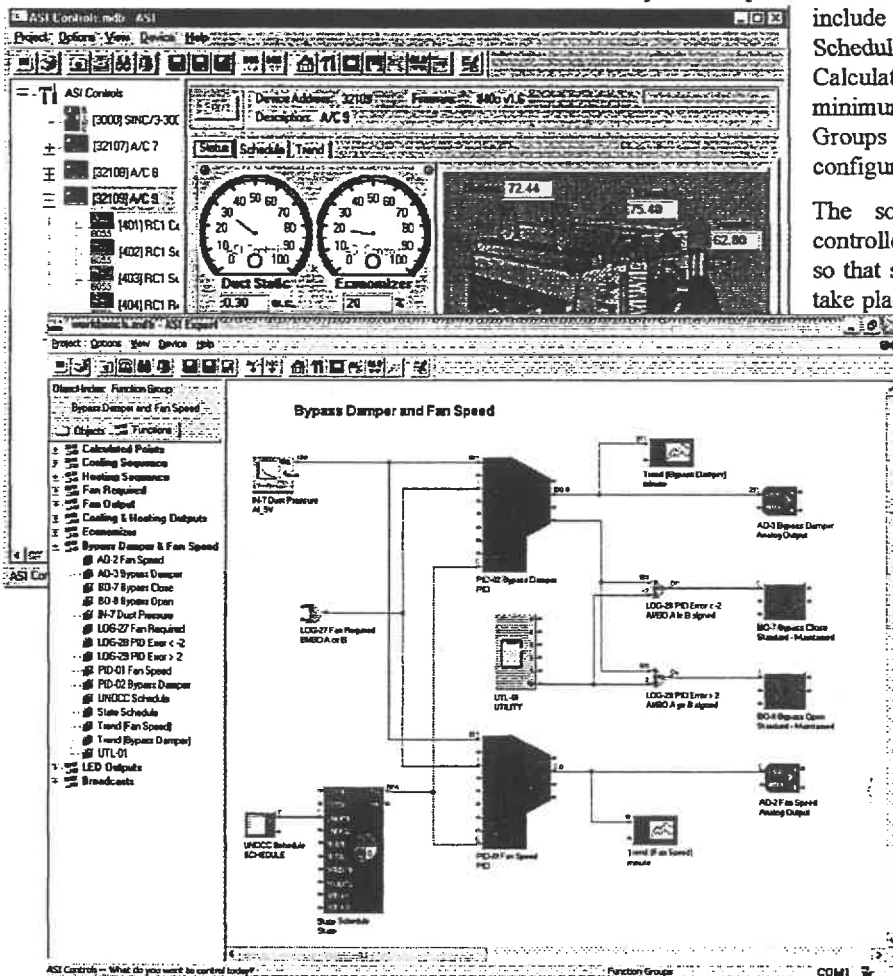



ASI CONTROLS

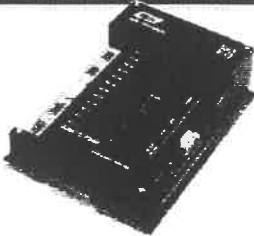

ASI Expert has two modes of access: Expert Mode and User Mode. In Expert Mode you have access to all features of the software including all configuration views for the ASIC/2 controllers. In User Mode access is restricted to only those views that have been designated. This allows developing custom views that are tied to specific controllers in the project.

In the on-line mode you communicate with the controller and changes are downloaded to the controller either immediately as the change is made, or sent to the controller after a series of changes have been made. Also, existing configurations can be downloaded to a controller on the bench.

In the off-line mode, a single device can be configured for later download to the controller. Controllers can be added to create an entire project tree for downloading to the actual controllers at the job site. Also, existing configurations can be imported and included in the project tree.

License

ASI Expert is licensed software. The license is for use on a specific computer, and only those features that are enabled are available to the user.

ASI Expert is licensed software and is shipped with a self-installing demo license which times out after 30 days. If a license file already exists on the machine, then it will not install a new one.

The first time ASI Expert is run, it installs on the customer machine and includes the hard disk serial number as part of the license. When the ASI Expert is launched then it displays the License.

System Requirements

ASI Expert software is designed to work on today's personal computers with Pentium processors or better, using It is a 32-bit application that includes high performance features that are not supported by older versions of Windows or PC hardware.

The minimum system should have :

- Pentium based Personal Computer
- Windows NT 4.0, Windows 2000, or Windows XP.
- 100 MB free hard disk space (includes pdf documentation).
- CD-ROM or network access to PC with a CD-ROM for installation purposes.
- Pointing Device. The software makes use of both right and left mouse buttons.
- At least one spare RS-232 serial communication port.

How to Order:	Order Number
ASI Expert Configuration Software	ASI Expert

All software is supplied on CD-ROM

Accessories:	Order Number
ASI OPC Server	OPC Server
EtherLink	EtherLink



ASI Controls

Multi-port System Interface

SINC/3 Features

- RS-232 Modem Access
- RS-232 Direct Access
- Real Time Hardware Clock
- Baud Rate Conversion at up to 19,200 baud
- Message Buffering
- Token Passing
- Local Bus Polling
- Dial-in, Dial-out
- Rx,Tx Indication

The SINC/3-3000 is a microprocessor based Multi-port System Interface that provides communication access to a network of ASI controllers from a system host computer or modem. The SINC/3 provides the electrical interface between the RS-232 full duplex communication, and four RS-485, 1/2 duplex balanced line communication buses. Red and green LEDs indicate receive and transmit status of the Direct, Modem, RS-232 ports and System and Local RS-485 communication busses. It communicates using ASI communication protocol messages at Up to 19,200 baud. The RS-485 inputs and outputs are protected with 1/8 A pico fuses. The 24 Vac power input is protected with a 1/2 A fuse.

The SINC/3-3000 supports dial-in or dial-out on a dedicated RS-232 modem port.

The SINC/3-3000 supports token passing on the System bus. It can also be configured as an RS-232 access device for a token passing system bus.

The SINC/3-3000 supports polling on the Local Busses and allows pass-through communication from the System bus, the Modem Access Port or the Direct Access Port to the local buses.

The SINC/3-3000 comes with a real time hardware clock and can broadcast time on the network and can be used to synchronize time on networks of ASIC/2 or ASIC/1 controllers.

The SINC/3-3000 can act as an optional baud rate buffer to allow networks communicating at differing baud rates to be linked. A typical application would be a modem link at 9600 baud connected directly to a control system at 19,200 baud. One could also add new controllers communicating at up to 19,200 baud to a building that has existing ASIC/1 controllers at 1200 baud.

The functions of the SINC/3-3000 are determined entirely by the configuration held in non-volatile EEPROM memory that retains program data during power interruption.

The controller is easily configured using Windows™ based ASI configuration software, ASI Expert, in a PC to set parameters such as Access and System Baud Rate, Access and System Bus Addresses. Comprehensive documentation is available in Windows™ Help format, which may be run in one window while setting up the controller in another window.





Specifications

Power Supply

Supply Voltage: 24 Vac @200 mA
 Power: 12 VA Maximum
 Fuse: 1/2 A fuse
 Optional: 10 Vdc @200 mA

RS-232 Communication (2)

Function : Direct Access DCE and Modem Access (DTE)
 Format: RS-232, full duplex
 Protocol: ASI Open Protocol
 Baud Rate: Selectable at 1200, 2400, 4800, 9600, or 19,200 baud.
 Access Address: 16 bit

RS-485 Communication (4)

Function : System Bus and 2 Local Busses
 Format: RS-485, 1/2 duplex, .
 Protocol: ASI Open Protocol
 Protection: 1/8 A Pico-fuse.
 Baud Rate: Selectable at 1200, 2400 4800, or 9600, or 19,200 baud.
 System Address: 16 bit

Indication

Power: Red LED
 Direct/Modem: 2-Rx Red and Tx Green LED
 Local/System: 2-Rx Red and Tx Green LED
 Status: 4 Amber LED

Terminations

Power: 24 Vac, 3 position screw terminal or +10 Vdc, Center Positive
 Optional Power Supply
 RS-232: Direct Access, DE-9 female (DCE) Modem Access, DB-9 male (DTE)
 RS-485: 4 each, 3 position screw terminals

Physical

Dimensions: Length 6.00" (152 mm) x
 Width 8.00" (2.03 mm) x
 Height 2.0" (51 mm)
 Mounting: Bracket, 0.75" x 9.0" (19 mm x 229 mm)
 2 Holes 8.5"(216 mm) on center
 Weight: 1.0 lb (0.45 kg)

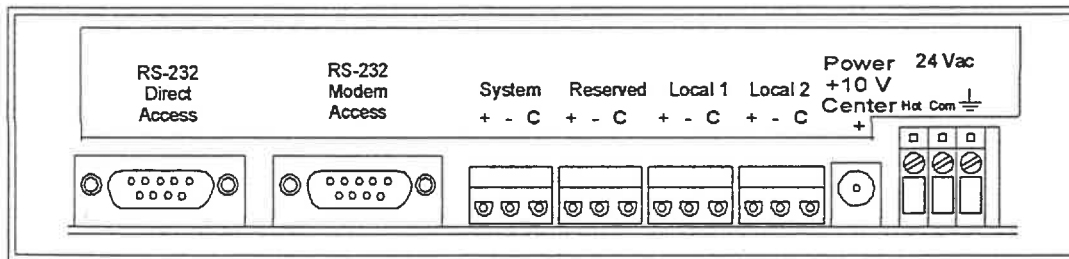

How to Order:	Order Number
SINC/3-3000 with enclosure	SINC/3-3000
SINC/3 Power Supply 10 Vdc/120 Vac	SINC/3-AC

Software & Documentation:	Order Number
ASI Expert Configuration Software	ASI Expert
SINC/3-3000 Users' Manual	3000 Manual

Accessories:	Order Number
ASI Compatible Modem	TELMODEM
Communication Pico Fuse Kit, Package of 10, 1/8 A picofuse	PFK-125



ASI Controls

Configurable System Controller

ASIC/2-7040 Features

- 16 Universal Inputs
- 12 Binary relay outputs
- 8 analog outputs
- 10 Year hardware clock
- System bus for communication access
- Local bus for supervision of terminal controllers
- Direct RS-232 communication user access
- Compatible with ASI WebLink & ASI Data Server products

The ASIC/2-7040 is a configurable unitary controller designed for energy management and control systems for a wide range of building systems including air handlers, chillers, cooling towers, pumps, lighting, etc. Applications range from autonomous control of retail stores, branch banks, and telephone company buildings to networked control of very large buildings.

The controller is easily configured using Windows™ based ASI Visual Expert configuration software that links ready-made objects for scheduling, PID control, alarming, optimum start, trending, run-time accumulation, event logging and electrical demand management. The ASIC/2-7040 has an on-board battery-backed calendar clock and allows special events, holidays, and schedules to be defined in advance. Configuration data is stored in non-volatile memory that is retained through power loss. Comprehensive product documentation is available on-line while using ASI Expert software.

In stand-alone applications a modem may be connected to allow dial-in from a remote location to review conditions and/or to modify schedules or setpoints. Under selected alarm conditions the controller can dial-out and send notify messages to a pager, printer, or computer running ASI Monitor software. Similarly, an ASI EtherLink can be attached to receive and send information via Ethernet TCP/IP network.

The controller has separate RS-485 system and local buses. The system bus is used to network multiple ASIC/2 controllers. The controllers may be polled or be configured for peer-to-peer communication using token passing. On a separate local bus the ASIC/2-7040 can poll ASIC/1 terminal controllers and make control decisions based on the data received. No central system is needed to supervise the controller. Red and green LEDs indicate the controller receive and transmit communications.

The ASIC/2-7040 can operate as part of a larger communicating control

network with other ASI controllers. Communication at speeds up to 19,200 baud means rapid access to information. This enables integrated control of the complete mechanical system to ensure optimum building performance. Temperatures, setpoints, and other controller information may be easily reported to ASI WebLink, or any Windows based software that is a client for OLE for Process Control (OPC) or Dynamic Data Exchange (DDE).

The twelve 24 Vac relay outputs are ideal for driving contactors and starters. Four yellow LEDs may be configured to indicate specific alarm or other conditions. The eight analog outputs are used for modulated actuators, electronic-pneumatic transducers, variable speed drives and other analog signal devices. The 16 universal inputs may be used for counting pulses, for reading thermistors and contact closures directly, and for reading 4 to 20 mA, 0 to 5 Vdc or 1 to 5 Vdc input signals.

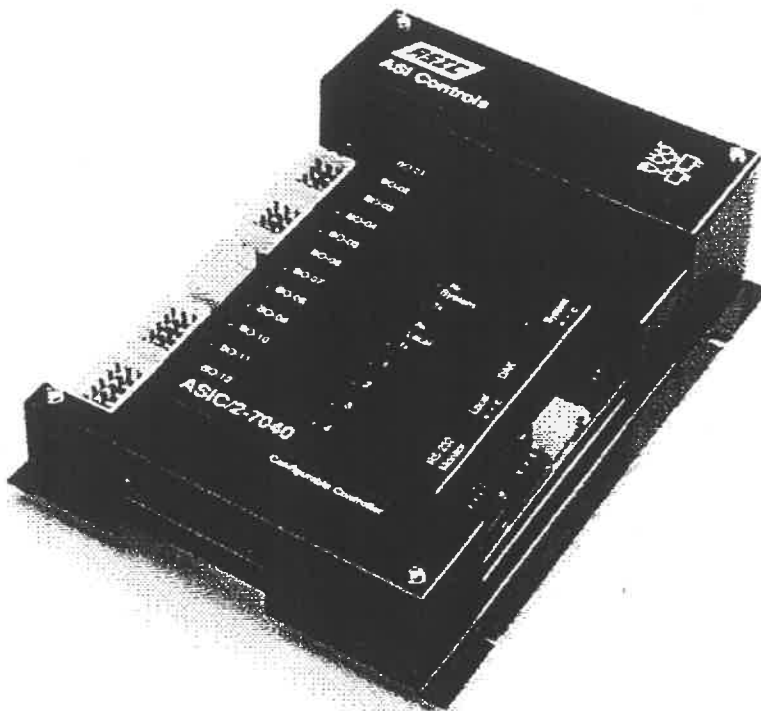



ASI Controls

Configurable System Controller

Features

Analog Input Monitoring	Binary Input Monitoring
Maintained Outputs	Pulsed Outputs
Tristate Outputs	Analog Outputs
Scheduled Start/Stop	Afterhour Override
Calendar Events	Special Day Schedules
Multiple Control States	Multiple PID Loop
Counters and Timers	Optional Demand Limit
Conditional Logic	Display and Keypad
Alarm Configuration	Value Trending
Polling Communications	Optional Token Passing
Local Bus Polling	Local Bus Broadcast
Hardware Clock	Brownout Protection

Specifications

Control Power

Supply Voltage: 24 Vac +/- 15%, 50/60 Hz
 Power Consumption: 24 VA (plus loads)
 Protection: 1 A Fuse

Binary Outputs 12

Type: Form "A" Relay SPST N.O.
 Dry Contacts
 Voltage Rating: 24 Vac or 24 Vdc, 2 A

Analog Outputs 8

Type: Analog 0-10Vdc
 Resolution: 0.4% full scale
 Current Rating: 5.0 mA at 10Vdc
 Optional Transient Voltage Suppressor Kit

Inputs 16

Type: Universal Analog/Binary
 Range: 0 to 5 Vdc
 Accuracy: 0.1% full scale

Communications

Format: RS-485 1/2 duplex
 RS-232 DB-9 Connector
 Baud Rate: 1200, 2400, 4800, 9600, 19200
 Protection: 1/8 A pico fuse,
 Transient Protection: 500 mW-s Transorb
 Maximum Length: 4000 ft (1.2 km) RS-485
 Repeater: ASI Converter/Repeater
 every 32 devices

System Bus Communication

Address Range: 32,001 to 32,255
 Maximum Size: Up to 255 devices with repeaters
 Baud Rate: Up to 19,200 baud

Local Bus Communication

Address Range: 1 to 32,000
 Maximum Size: Up to 64 devices with repeaters
 Maximum Baud Rate: Up to 9600 baud

Specifications Continued

Connections

Power: Molex 3 pin plug connector
 Input: 2 Molex 15 pin plug connector
 Binary Output: 2 Molex 12 pin plug connector
 Analog Output: Molex 15 pin receptacle connector
 Communications: 2, 3 Position, screw terminals
 Mini-Molex 8 pin connector for DAK-002-E
 9 position DE-9 female for RS-232

Other

Microprocessor: Intel 80C196 microcontroller
 Memory: Firmware, 512 kbits EPROM
 Volatile, 32kbytes RAM
 Non-volatile, 32 kbytes EEPROM
 Indication: 1 Red LED, Power
 2 Red LED Receive, 2 Green LED Transmit
 4 Amber LED programmable.
 12 Red LED, Binary Outputs

Overall Dimensions with base:

7.7" x 10.2" x 2.5" (WxLxH)
 196 mm x 259 mm x 64 mm
 with mounting holes on center
 7.2" x 7.2" (183 mm x 183 mm)
 Weight: 4.4 lb (2.0 kg)

Environmental

Operating: 0 to 40 °C (32 to 104 °F)
 10 to 95% rh non-condensing
 Storage: -37 to 80 °C (-35 to +180 °F)
 5 to 95% rh non-condensing

UL Listing

Open Energy Management



Rated as a Class 2 Device, Pilot Duty
 Includes MCK-003 Molex connector kit with wiring instructions
 Use provided connectors. Meets CE requirements.

How to Order:	Order Number
Configurable Controller with enclosure	ASIC/2-7040

Accessories:	Order Number
Three Input Multiplex Kit	MUX-124
Transient Voltage Suppressor Kit, 10 Vdc	TVS-10

Software & Documentation:	Order Number
ASI Expert Configuration Software	ASI Expert
ASIC/2-7040 Object Definitions	7040 OBJ DEF
ASIC/2-7040 Users' Manual	7040 Manual



ASI Controls

Configurable System Controller

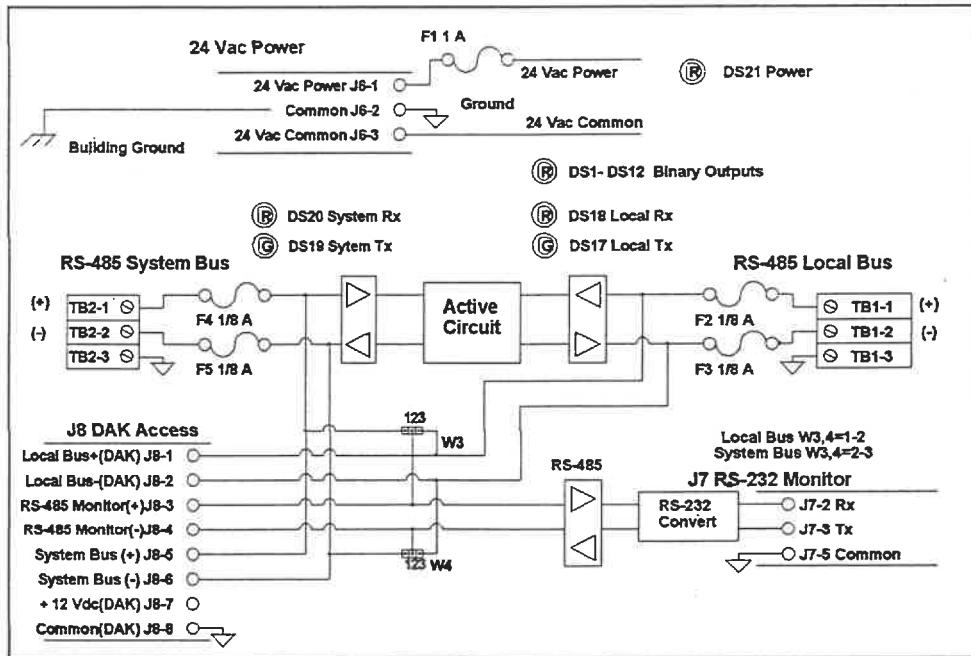
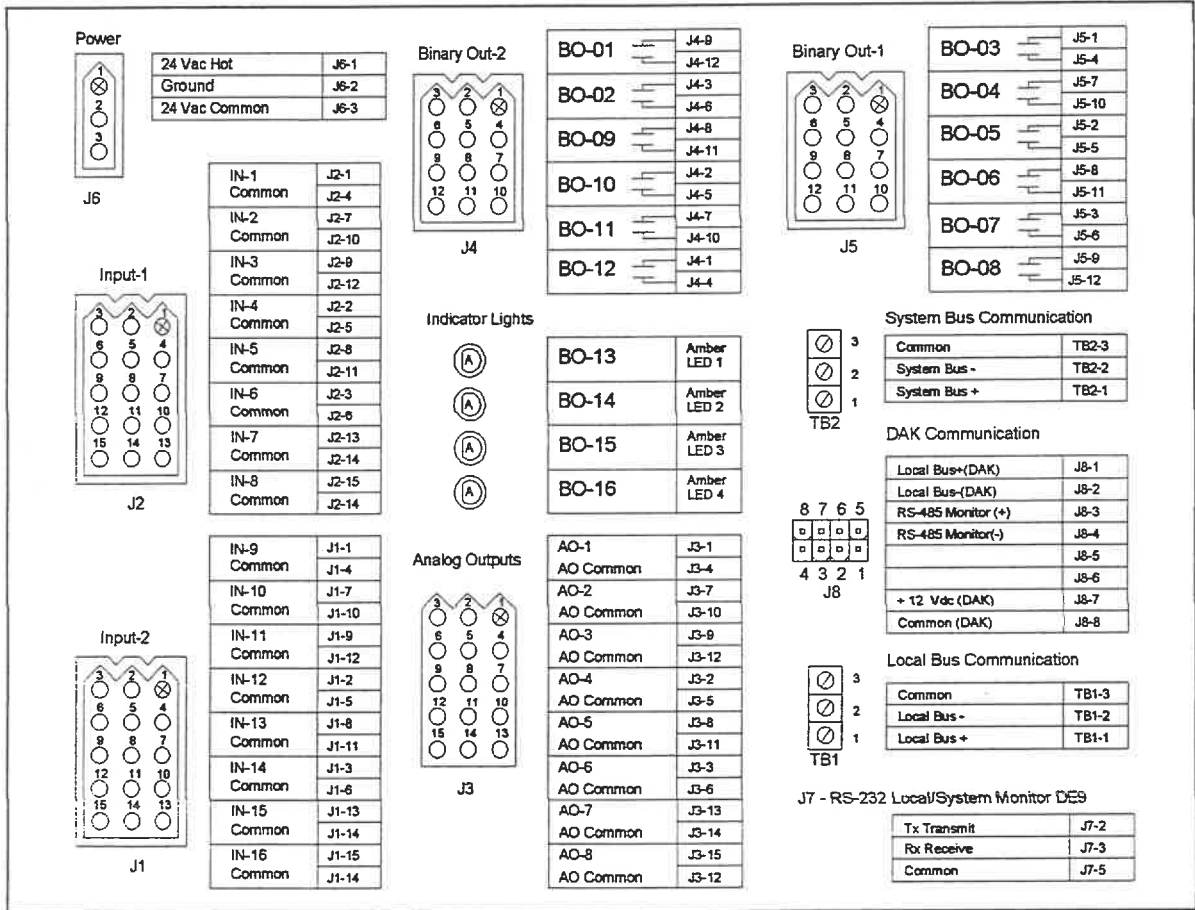

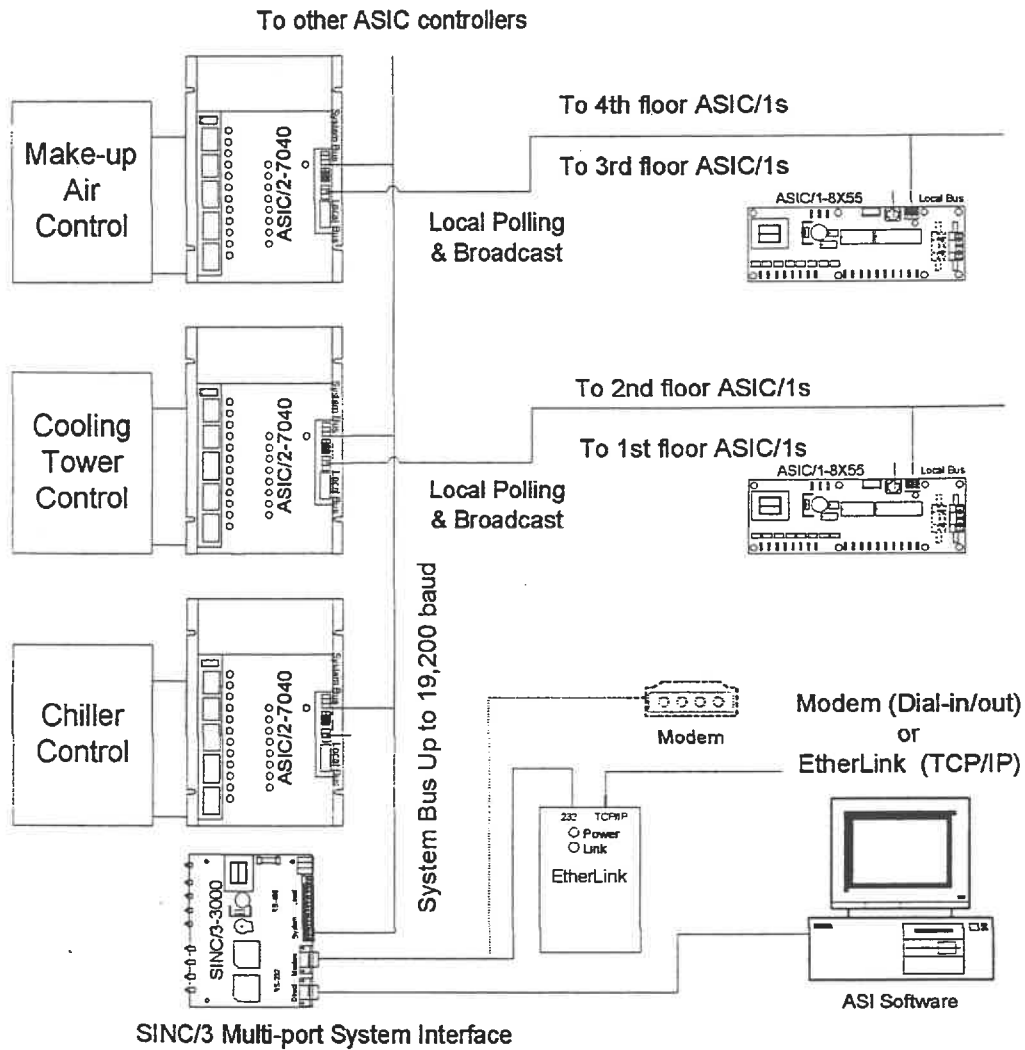

Typical ASIC/2-7040 System Layout

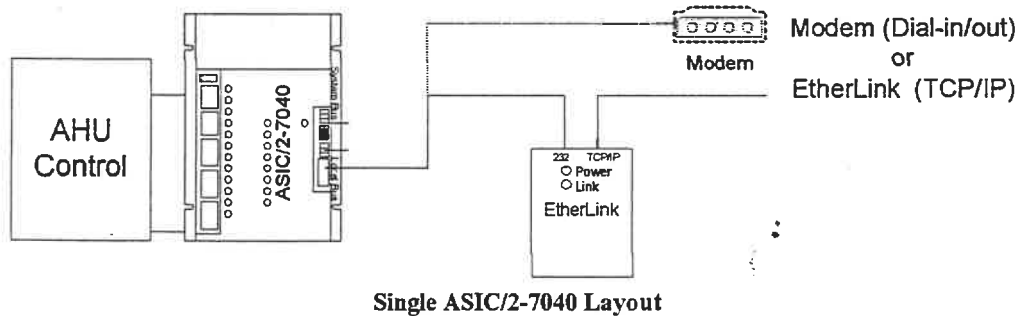



ASI Controls

Integrated VAV Controller

ASIC/1-6000 Features

- Integrated Damper Actuator
- Compatible with WS-051 Digital Wall Sensor
- Sequences include:
 - Cooling Damper Only
 - Hot Water or Electric Heat
 - Intermittent or Constant Fan
- Features include:
 - Auto-Changeover
 - Lighting Control
 - Variable User Adjust
 - After-hours Override
 - Trending
- Calibrated on-board airflow sensor
- Compatible with ASI WebLink & ASI Data Server Products
- Flash programmable firmware

The ASIC/1-6000 is a pre-programmed communicating digital controller with an integral damper actuator for the control of pressure independent Variable Air Volume (VAV), and Fan-Powered VAV terminal units. The controller includes an on-board airflow sensor and maintains the space temperature by varying the air volume. The controller monitors zone temperature through the WS-0X1 Wall Sensor and calculates the correct air volume to be distributed to the space based upon comparing this temperature with the cooling and heating setpoints.

This pressure independent controller is mounted on the VAV terminal being controlled. Attach the motor to the damper shaft, and secure the controller with the anti-rotation screw. The controller contains the most frequently used VAV applications and has personalities for cooling only, and cooling with hot water or electric reheat, and constant or intermittent fan.

No user programming or calibration is necessary. To be fully operational, the operator needs only to enter a unique device address, select the correct personality for the application and verify or modify duct area and airflow K-factors.

The ASIC/1-6000 may be used for both new construction and retrofit applications. The pre-configured controller allows newly installed zones to be started up quickly and efficiently. Pre-tuned PI algorithms mean that controllers can accurately maintain space temperature.

The controllers include after-hours override, user temperature adjustment, and lighting control features. Afterhours usage is automatically stored at each unit for retrieval by the building operator. Time-based features such as scheduled changes in setpoints and lighting control may be used when the controller is connected in a network and can be synchronized by broadcast time message.

The ASIC/1-6000 can operate-stand alone or as part of a larger communicating control network with other ASI controllers. Communication at speeds up to 19,200 baud means rapid access to information. This enables integrated control of the complete mechanical system to ensure optimum building performance. Temperatures, airflow, setpoints, and other controller information may be easily reported to ASI WebLink, or to any Windows based software that is a client for OLE for Process Control (OPC).

The ASIC/1-6000 has flash programming. The firmware can be upgraded over the local RS-485 communications bus.

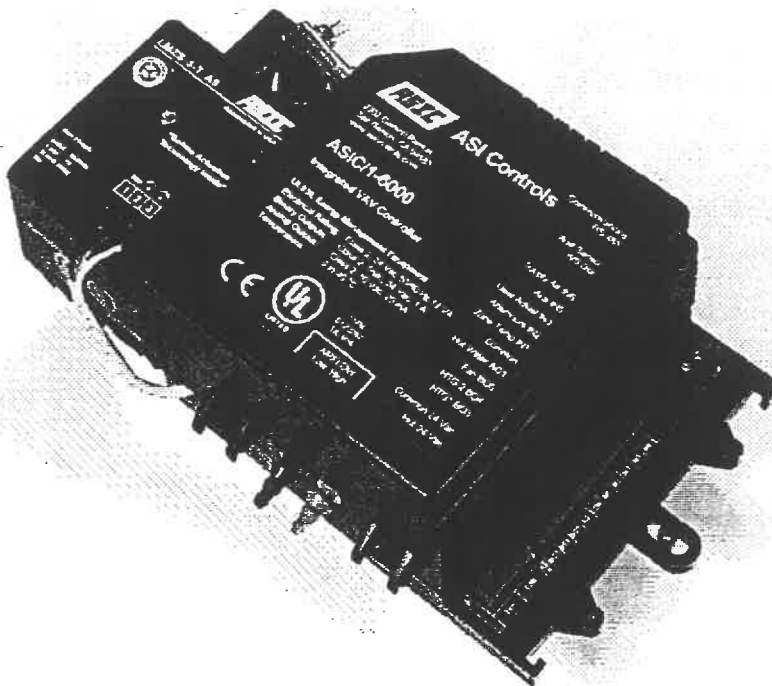



ASIC/1-6000

ASI Controls

Integrated VAV Controller

Specifications

Control Power

Supply Voltage: 24 Vac +/- 15%, 50/60 Hz
Power Consumption: 6 VA (plus loads)

Binary Outputs 5

Type: 5 Binary solid state switch
Voltage rating: 24 Vac, 1 Amp, MOV protected

Damper Motor

Type: Brushless
Torque: 35 in-lb (4 N-m)
Drive time: 95 s
Power: 24 Vac, 3 VA

Analog Outputs 1

Voltage rating: 0-10 Vdc, 20 mA

Inputs 6

Type: Universal Analog/Binary
Range: 0 to 5 Vdc, 10 bit, 0.1% full scale
Temperature Sensor: WS-0X1, WS-051
3 kohm at 77 °F (25 °C) thermistor.
Air Flow Sensors: 1, Integral solid state AWM 3300.
Control Resolution: 25 FPM at K-factor = 2338.
Range: 0 to 3300 FPM
Maximum Error for all reasons: +/- 5% Full Scale

Communications

Format: RS-485 1/2 duplex
Protection: 100 mA polyswitch
500 mW-s TVS
Baud Rate: 1200, 9600, or 19,200
Repeater: ASI Converter/Repeater
every 32 devices

Connections

Power and I/O: Screw Terminal
Communications: 3-position screw terminals
Zone Sensor: 8-position, modular jack, RJ-45
for use with ASI cable SCP-0XX
Screw Terminal

Other

Indication: 3 LEDs, Power, Rx/Tx
Dimensions: 5.9" x 8.9" x 2.5"
150 mm x 225 mm x 64 mm
Weight: 1.66 lbm (0.76 kg)

Environmental

Operating: 0 to 45 °C (32 to +113 °F)
10 to 95% rh non-condensing
Storage: -37 to 80 °C (-35 to +180 °F)
5 to 95% rh non-condensing

UL Listing

UL-916 Open Energy Management Equipment
File E123287 (PAXZ) Class 2 Device



Meets CE Requirements.

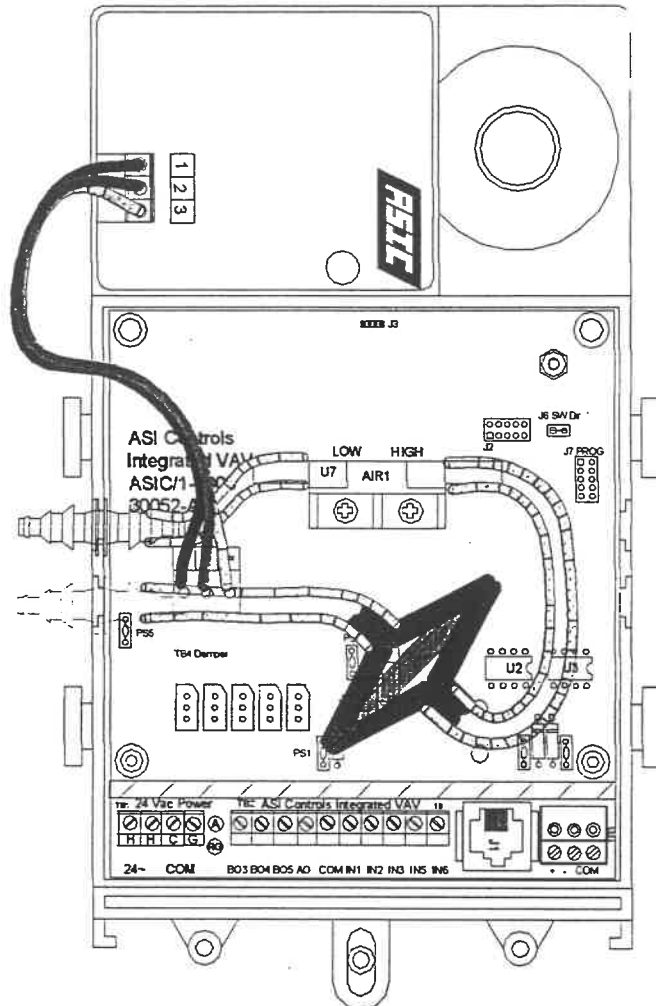

How to Order:	Order Number
VAV Controller with Actuator	ASIC/1-6000

Accessories:	Order Number
Wall Temperature Sensor	WS-0X1
Digital Display Wall Sensor	WS-051
Sensor Cable	SCP-0XX

Software & Documentation:	Order Number
ASI Expert Configuration Software	ASI Expert
ASIC/1-6000 Users' Manual	6000 Manual

ASI Controls

Wall Sensor with Digital Display

WS-051 Features

- Digital display of room ambient temperature and user selected temperature setting on demand
- 11 Icons and 4 digit LCD display
- Adjustable Occupied heating and cooling setpoints
- Pushbutton selection of display mode
- Push-button selection of afterhours operation
- Selectable °C or °F display
- Self-diagnostic features

The WS-051 Digital Display zone temperature sensor is used in conjunction with the ASIC/1-8055 or ASIC/1-8655 controller for measuring ambient zone temperature, for displaying and modifying the Occupied Heating and Cooling Temperature Setpoints, and for initiating afterhours operation.

The wall mounted sensor utilizes a precision thermistor to measure zone temperature and deliver an analog signal to the ASIC/1 controller. The thermistor's high change of resistance creates a large signal that eliminates lead wire resistance problems. When connected to a ASIC/1 controller the WS-051 displays the Zone Temperature used by the ASIC/1 for control.

Features include telephone type 8-pin modular connector for easy connection to controller and trouble free installation using the SCP-xxx sensor cable. A communication jack at the bottom provides operator access for the portable SINC/1-1030 Mini-SINC connected to a laptop or PocketPC computer. Using ASI Expert software, the user is able to read and reset the setpoints and parameters of the local controller as well as other ASIC/1 controllers. Air balancing, setpoint adjustment and all system startup can be accomplished from the WS sensor.

Application

The sensor is shipped ready to be connected to the ASIC/1-8055 or ASIC/1-8655 controller which have appropriate firmware version. On the ASIC/1-8055 the second RS-485 chip, U1, must be in place. The pin-socketed pull-up resistor for Input 2 **must be removed and replaced** with a 1/8 A pico-fuse to provide 5 Vdc power from the ASIC/1 to the WS-051 over the standard SCP-0xx sensor cable. The Digital Display option **must be enabled** in the controller.



Normal Operation

Normally the numeric display shows the Zone Temperature. If the controller is configured for Fahrenheit or Celsius, then the °F or °C icon is displayed. If the Active Control Mode is Heating or Cooling, then the Heat or Cooling Icon is displayed. If the Active Control Mode is Deadband, then they are NOT displayed.

If the Active Control State is Occupied or Morning Ready, then the Day Icon is displayed. If the Active Control State is Unoccupied, then the Day Icon is off. If the Active Control State is Night Setback, then the Night Icon is displayed.

If the personality is Constant or Intermittent Fan and the Fan is ON, then the Fan Icon is displayed.

User Adjust Operation

Pressing the Mode key brings up User Adjust Operation and displays the Occupied CLG Setpoint. Pressing the Override key while in User Adjust Operation toggles to the Occupied HTG Temp SP or back to the Occupied CLG Temp SP. The Setpoint icon is displayed. When the Up or Down key is pressed, the displayed Occupied Temp Setpoint is incremented or decremented by either 1degree or 0.5 degree depending on the option selected.



ASI Controls

Wall Sensor with Digital Display

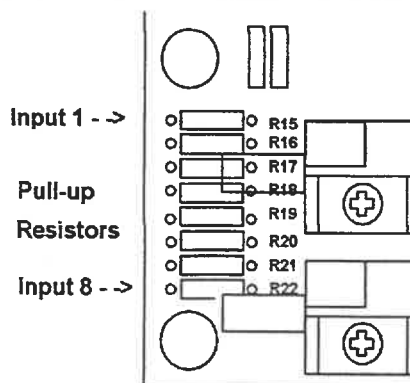

ASIC/1-8055: Replace pull-up resistor, R16, with 1/8 A pico-fuse.

Saving Setpoints

The CLG and HTG Temperature setpoints are limited by the Upper Limit Temp SP and the Lower Limit Temp SP. A 2 count separation between the Occ CLG Temp SP and the Occ HTG Temp SP is enforced. If Half degree Enable is set in the controller, then 1 count is 0.5 deg.

The new setpoints are saved by pressing the mode key , or by simply waiting for 30 seconds for it to return to default operation.

Override Operation

Pressing the Override key from default operation triggers afterhours operation. If the Active Control State is Unoccupied or Night Setback, it triggers afterhours operation and the "In Afterhours" clock Icon is displayed. If the active control state is Occupied or Morning Ready it has the effect of toggling the lights on or off.

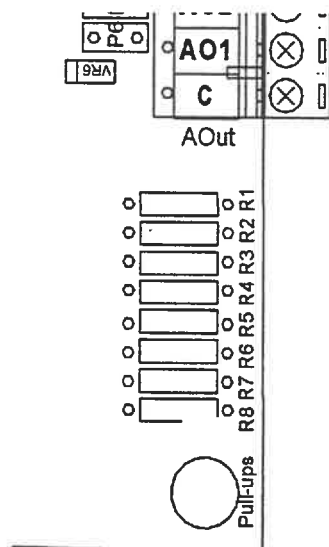

ASIC/1-8655: Replace pull-up resistor, R2, with 1/8 A pico-fuse.

SPECIFICATIONS

- Sensor: NTC thermistor, 3000 Ohm at 25.0 °C (77 °F)
- Temperature Indication: 32 °F to 104 °F, 0 to 40 °C
- Indication Accuracy: +/- 0.5 °C (+/- 1°F)
- Setpoint Adjust: Mode Selection and Up and Down Arrows
- Push-Button: O/R Button
- Power: Less than 50 mA, 5 Vdc from ASIC/1 through 1/8 A pico-fuse on input #2
- Operator Access: 6 position female modular jack, RJ-12, for use with portable SINC/1-1030
- Connections: 8 position female modular jack, RJ-45 in rear for use with ASI cable SCP-025, -050 or -075
- Dimensions: Standard 4.50" x 2.75" x 1.25" (115mm x70mm x32mm)
- Setpoint Range: 15~30 °C (59~86 °F)
- Display: LCD, 11 icons and 4 digit
- Display Unit: 0.1 °C (0.1 °F) / step
- Setting Unit: 0.5 °C (0.5 °F) / step
- Operating Temperature: 0~50 °C (32~122 °F)
- Operating Humidity: 5~95% RH (non-condensing)
- Storage Temperature: 0~80 °C (32~176 °F)
- Mounting: Mounts directly onto wall or standard 2x4 inch vertical junction box (hole pitch 83.5 mm)

How to Order:	Order Number
Wall Sensor with Digital Display	WS-051

Thermistor Temperature Sensors

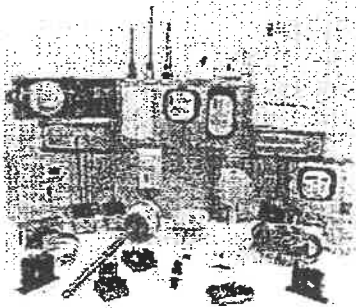

ACI/2252 Series
ACI/3K Series
ACI/5K Series
ACI/10K-AN (Type III)
ACI/10K-CP (Type II)

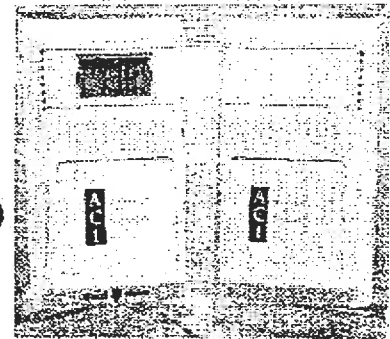

Product Description

The ACI/2252, ACI/3K, ACI/5K, ACI/10K-AN (Type III), and ACI/10K-CP (Type II) Series temperature sensors are thermistor type sensors. These sensors provide a predictable output over a specified temperature range to meet each manufacturer's required input values.

Thermistors offer high accuracy and interchangeability over a wide temperature range.

The thermistors higher resistance relative to Platinum RTD's, creates a larger signal with the same measuring current, negating most lead wire resistance problems and eliminating the need for signal conditioners.

These units are offered in Room, Room with Set Point, Room with Override, Room with Setpoint and Override, and Room w/ Setpoint, Override, and RJ11 Jack, Stainless Steel Duct and Duct without Box, Immersion, Stainless Plate, Raw, Bendable Copper and Stainless Steel Rigid Averaging, Strap-On, Bullet Probe, Button Sensor, and Outdoor Air Configurations.

Setpoint options include a linear 400 Ohm, 1K, 2K, 3K, 5K, 8.5K, 10K, 20K, or 100K slide potentiometer. An optional series resistor allows for any offset of the setpoint potentiometer. These may be either Direct or Reverse Acting.

Indication stickers for setpoint include Cool/Warm, 55 to 85, and 10 to 30°C. Others are available upon request.

Override options include a N/O switch in parallel with the sensor or a separate 2 pole terminal block for Tenant override.

All ACI sensors can be ordered with an optional 4 pin RJ11 or 6 pin RJ12 or 1/8" RS232 Stereo communication jack with terminal blocks for remote programming.

All units come with a two year factory warranty. Please contact ACI for more information regarding these products.

Product Specifications

Output	2,252 Ohms @ 77°F(25°C)	Dissipation Constant	3 mW / °C
	3,000 Ohms @ 77°F(25°C)		
Temperature Range	5,000 Ohms @ 77°F(25°C)	Stability	+/- 0.13°C
	10K Ohms @ 77°F(25°C) Type II		
	10K Ohms @ 77°F(25°C) Type III		
Interchangeability	-40 to 302°F (-40 to 150°C)	Accuracy	+/- 0.2°C (0 to 70°C)
	+/- 0.2°C (0 to 70°C)	Operating Humidity	0 to 90% RH non-condensing

2305 Evergreen Rd. Middleton Industrial Park Middleton, WI 53562
PH: (608) 831-2585 FAX: (608) 831-7407

Dimensions

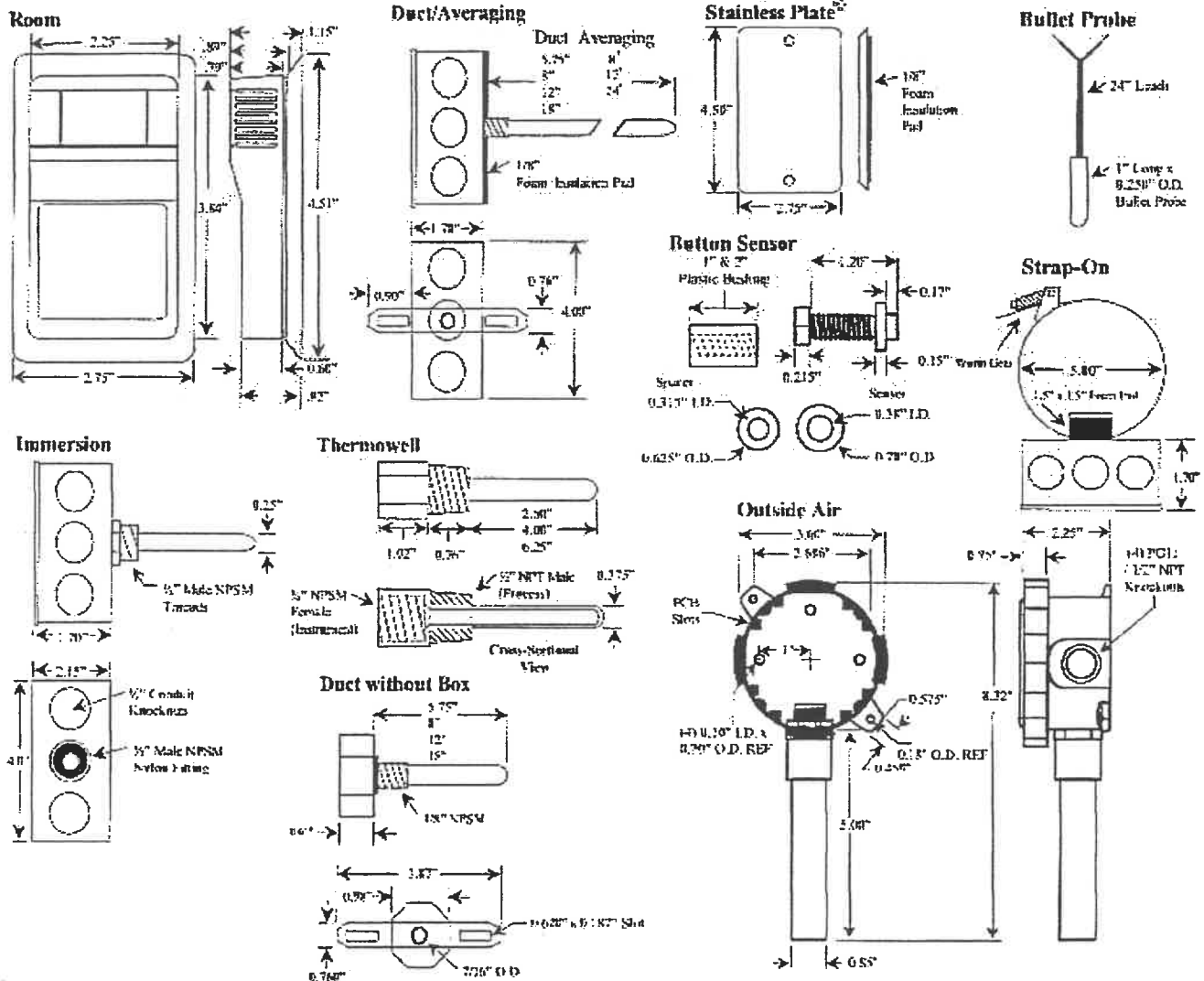

Ordering Information

Sensor	Configuration	Communication Jack	Pot Value	Setpoint Indication	Pot Action
A/)	-)	-)	-)	-)	-)
↑	↑	↑	↑	↑	↑
2252	R - Room	RJ4 (4 Pin RJ11)	400 Ohm	Cool Warm	DA (Direct)
3K	RS - Room w/Setpoint	RJ6 (6 Pin RJ12)	1K	55 to 85	RA [Reverse]
5K	RO - Room w/Overrides	232 (1/8" Stereo Jack)	2K	10 to 30°C	
AN (10K-AN)	RSO - Room w/Setpoint & Override		3K	Specify	
CP (10K-CP)	D - Duct 4", 8", 12", 18"		5K		
	DO - Duct without Box 4", 8", 12", 18"		8.5K		
	I - Immersion 2.5", 4", 8"		10K		
	A - Averaging 8", 12", 24"		20K		
	RA - Rigid Averaging 18", 24", 36"		100K		
	S - Strap-On				
	O - Outdoor Air				
	BP - 1" Bullet Probe				
	RP - Remote Probe 6' Lead wire				
	SP - Stainless Plate				
	W - Raw w/18" Leads				
	BBS - Brass Button Sensor				
	SBS - Stainless Button Sensor				

Example: A/AN-RSO-RJ6-20K-55 to 85-DA or A/3K-D-8" or A/AN-RSO-232-20K-RA-Cool/Warm

2305 Evergreen Rd. Middleton Industrial Park Middleton, WI 53562

PH: (608) 831-2585 FAX: (608) 831-7407

Thermistor R/T Curve Table

ACI Temp °C	ACI Temp °F	ACI/2252 Resistance Ohms	ACI/3K Resistance Ohms	ACI/5K Resistance Ohms	ACI/10K-AN Resistance Ohms	ACI/10K-CP Resistance Ohms
-40	-40	75,769.0	100,935.0	168,225.0	239,686.0	336,450.0
-35	-31	54,647.0	72,798.0	121,330.0	179,200.0	242,660.0
-30	-22	39,851.0	53,088.0	88,480.0	135,185.0	176,960.0
-25	-13	29,368.0	39,123.0	65,205.0	102,861.0	130,410.0
-20	-4	21,861.0	29,122.0	48,536.0	78,913.0	97,072.0
-15	5	16,429.0	21,885.0	36,476.0	61,020.0	72,951.0
-10	14	12,459.0	16,598.0	27,663.0	47,543.0	55,326.0
-5	23	9,532.0	12,698.0	21,163.0	37,313.0	42,326.0
0	32	7,353.0	9,795.0	16,325.0	29,490.0	32,650.0
5	41	5,718.0	7,617.0	12,696.0	23,457.0	25,391.0
10	50	4,481.0	5,970.0	9,950.0	18,780.0	19,899.0
15	59	3,538.0	4,713.0	7,856.0	15,130.0	15,711.0
20	68	2,813.0	3,748.0	6,246.0	12,263.0	12,492.0
25	77	2,252.0	3,000.0	5,000.0	10,000.0	10,000.0
30	86	1,814.0	2,417.0	4,028.0	8,194.0	8,057.0
35	95	1,471.0	1,959.0	3,266.0	6,752.0	6,531.0
40	104	1,200.0	1,598.0	2,663.0	5,592.0	5,326.0
45	113	983.8	1,311.0	2,184.0	4,655.0	4,368.0
50	122	811.2	1,081.0	1,801.0	3,893.0	3,602.0
55	131	672.5	895.8	1,493.0	3,271.0	2,986.0
60	140	560.3	746.3	1,244.0	2,760.0	2,488.0
65	149	469.0	624.8	1,041.0	2,339.0	2,083.0
70	158	394.5	525.5	875.8	1,990.0	1,752.0
75	167	333.1	443.8	739.7	1,700.0	1,479.0
80	176	282.7	376.6	627.6	1,458.0	1,255.0
85	185	240.9	320.9	534.9	1,255.0	1,070.0
90	194	206.2	274.6	457.7	1,084.0	915.4
95	203	177.1	236.0	393.3	939.3	786.6
100	212	152.8	203.6	339.3	816.8	678.6
105	221	132.3	176.3	293.8	712.6	587.6
110	230	115.0	153.2	255.3	623.6	510.6
115	239	100.3	133.6	222.6	547.3	445.2
120	248	87.7	116.9	194.8	481.8	389.6
125	257	77.0	102.6	171.0	425.3	341.9
130	266	67.8	90.3	150.5	376.4	301.0
135	275	59.9	79.7	132.9	334.0	265.8
140	284	53.0	70.6	117.7	297.2	235.4
145	293	47.1	62.7	104.5	265.1	209.0
150	302	41.9	55.8	93.0	237.0	186.1

Freeze Stats

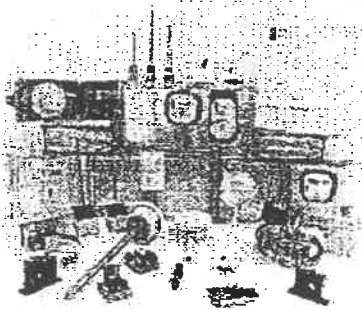

ACI/FS Series

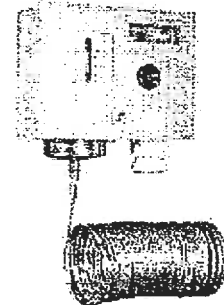

Product Description

The ACI/FS Series controllers are Low Limit controllers also known as "Freeze Stats". These devices were designed for use on all HVAC equipment requiring low-temperature indication in ducts or on heating and cooling coils.

The FS-1, FS-3 and FS-5 are available in both manual and automatic reset versions. These units are responsive to the lowest temperature sensed along any 1 foot of the sensing element. They also have (1) set of SPDT contacts with an adjustable setpoint range of 14 to 54°F. The sensing element is made up of a vapor-filled, copper capillary tube measuring 5/64" in diameter with an overall length of 6, 10, and 20 feet depending on the model number.

The FS-2, FS-4, and FS-6 are available in both manual and automatic reset versions. These units are responsive to the lowest temperature sensed along any 1 foot of the sensing element. The FS-2, FS-4, and FS-6 has (2) sets of SPDT contacts with an adjustable setpoint range of 14 to 54°F. The sensing element is made up of a vapor-filled, copper capillary tube measuring 5/64" diameter with an overall length of 6, 10, or 20 feet depending on the model.

All of these units come with a two year factory warranty. Please contact ACI for more information regarding any of the ACI/FS series Freeze Stats.

Product Specifications

Input	Vapor Filled, Copper Capillary tube	Operating Temp. Range	14 to 194°F (-10 to 65°C)
Output	FS-1, FS-3, FS-5 Contacts (1 Set SPDT) FS-2, FS-4, FS-6 Contacts (2 Sets SPDT)	Maximum Operating Temp. of Sensor	392°F (200°C) max. 1 hour
Reset Type	Manual Reset	Setpoint Differential	1.8°F (1°C), Fixed for Auto Reset
Setpoint Range	14 to 54°F (-10 to 12°C) Field Adjustable	Setpoint Safety Lock	35.6°F (Factory Set), Field Adjustable
Housing Rating	NEMA1 (IP40)	Wire Size	Maximum 14 awg Wire
Approvals	CE	Contact Rating	250 VAC, 15 (8) A
Weight	2.0lbs (0.9Kg)	Approvals	14 to 54°F (-10 to 12°C) Field Adjustable

2305 Evergreen Rd. Middleton Industrial Park Middleton, WI 53562

PH: (608) 831-2585 FAX: (608) 831-7407

Dimensions

ACI/FS-1

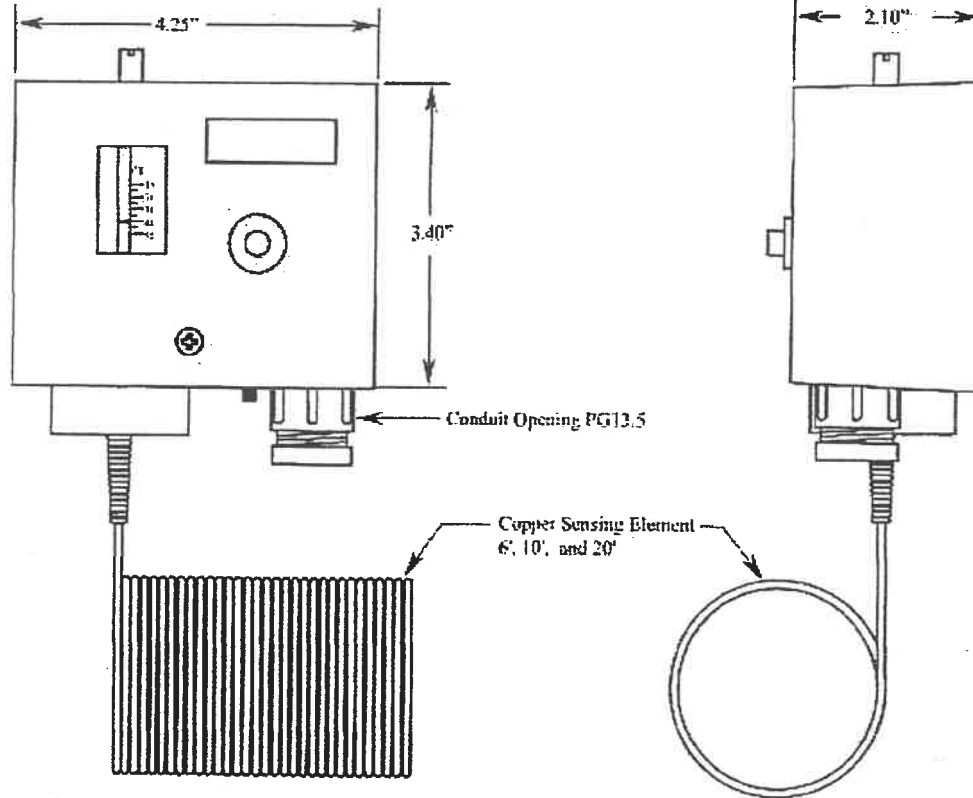

Ordering Information

Models
A / I / 1
↑

- FS-1 ((1 set) SPDT Contacts, 20ft capillary, Manual reset)
- FS-1A ((1 set) SPDT Contacts, 20ft capillary, Auto reset)
- FS-2 ((2 sets) SPDT Contacts, 20ft capillary, Manual reset)
- FS-2A ((2 sets) SPDT Contacts, 20ft capillary, Auto reset)
- FS-3 ((1 set) SPDT Contacts, 10ft capillary, Manual reset)
- FS-3A ((1 set) SPDT Contacts, 10ft capillary, Auto reset)
- FS-4 ((2 sets) SPDT Contacts, 10ft capillary, Manual reset)
- FS-4A ((2 sets) SPDT Contacts, 10ft capillary, Auto reset)
- FS-5 ((1 set) SPDT Contacts, 6ft capillary, Manual reset)
- FS-5A ((1 set) SPDT Contacts, 6ft capillary, Auto reset)
- FS-6 ((2 sets) SPDT Contacts, 6ft capillary, Manual reset)
- FS-6A ((2 sets) SPDT Contacts, 6ft capillary, Auto reset)
- DBZ-05 Capillary Mounting Clips (Set of 6)
- DBZ-07 Housing Mounting Bracket

Example: A/FS1 or A/FS-1A or A/FS-2 or A/FS-2A

2305 Evergreen Rd. Middleton Industrial Park Middleton, WI 53562

PH: (608) 831-2585 FAX: (608) 831-7407

Control Transformers

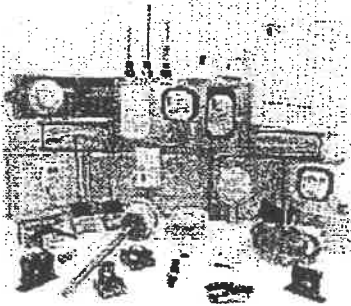

ACI/LE Series

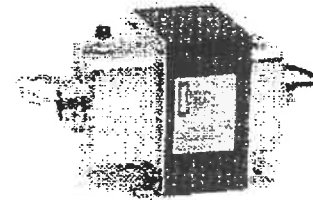

Product Description

The ACI/LE series control transformers are designed to provide a stable, clean and reliable 24 VAC power source. Many different styles and VA output ranges are available upon request. All of our transformers are UL and CUL or CSA approved.

Mounting configurations are available with 1/2" conduit hubs and mounting feet. Single and multiple primary input transformers are available in ranges from 40 to 150 VA. A manual reset circuit breaker pushbutton is used in some of the models. All of our transformers also

incorporate a Class F, 150 insulation system.

Some of the common applications are:

- Lighting Controls
- Isolation Transformers
- Powering peripheral devices such as valves, motors, controllers, and thermostats

All of the transformers come with a two year factory warranty. Please contact ACI, for more information regarding any of the transformers.

Product Specifications

Primary Supply Voltage	24 to 480 VAC (See ordering information)	VA Output Ranges	40 to 150 VA
Overload Protection	Manual Reset Circuit Breaker or 75° Thermal cutout	Operating Humidity	0 to 95%, non-condensing
Approvals	UL and CUL or CSA		

Dimensions

All Dimensions are in Inches

LE1175

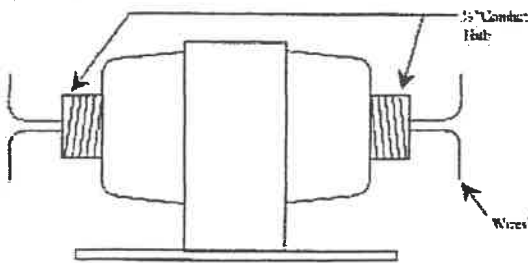

LE105 and LE117

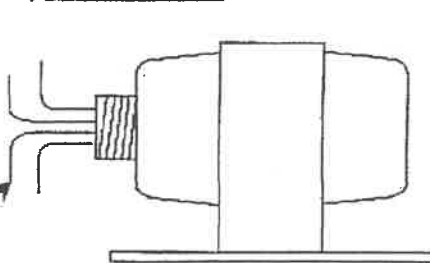

LE118, LE120 LE15013

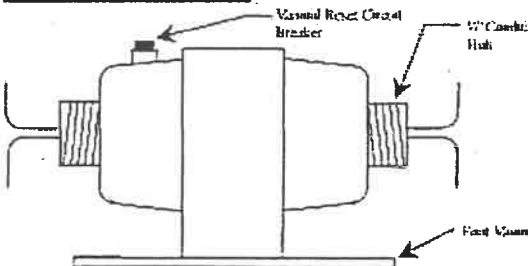

LE119, LE160

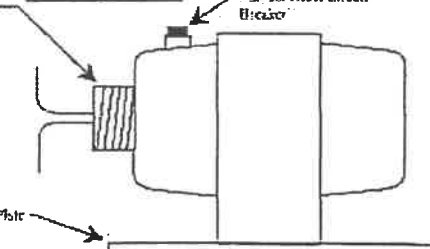

LE160 and LE1501

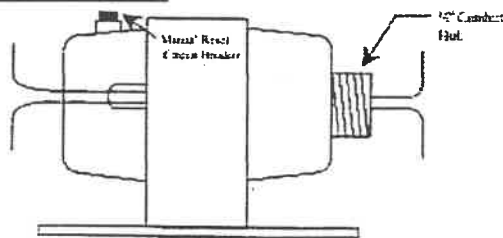

Dimensions

Model #	L X	W X	H
LE105	2.70"	2.19"	2.88"
LE117	2.82"	2.19"	2.88"
LE118	3.90"	2.52"	3.00"
LE119	4.10"	2.52"	3.00"
LE120	4.10"	2.50"	3.00"
LE124	3.47"	3.80"	3.30"
LE160	3.50"	2.52"	3.00"
LE1175	2.83"	2.19"	2.88"
LE1501	3.91"	2.54"	3.00"
LE15013	3.91"	2.54"	3.00"

Ordering Information

Model # ACI/LE-[]	Primary Voltage	Secondary Voltage	VA	#Hubs	Manual Reset*	Approvals**
105	24 VAC, 50/60 Hz	24 VAC	40	1	TC	UL, US & Canada E196572
117	120 VAC, 50/60 Hz	24 VAC	50	1	TC	CSA LR108412-2, UL E173056
118	120 VAC, 50/60 Hz	24 VAC	75	2	3.75 A	CSA LR108412-3, UL E173056
119	120 VAC, 50/60 Hz	24 VAC	75	1	3.75 A	CSA LR103412-3, UL E173056
120	120 VAC, 50/60 Hz	24 VAC	96	2	4.00 A	CSA LR108412-4, UL E173056
124	120 VAC, 50/60 Hz	24 VAC	150	1	10 A	UL, US & Canada E177644
160	120, 240, 277, 480 50/60 Hz	24 VAC	50	2	2.25 A	CSA LR103412-3, UL E163331
1175	120 VAC, 50/60 Hz	24 VAC	50	2	TC	CSA LR108412-4, UL E173056
1501	120, 208, 240, 480 50/60 Hz	24 VAC	75	1	3.75 A	CSA LR108412-3, UL E173056
15013	120, 208, 240, 480 50/60 Hz	24 VAC	75	2	3.75 A	CSA LR108412-3, UL E173056

*Note: TC represents all of the transformers with a 75°C thermal cutoff

**Note: All UL listings are for both the U.S. and Canada

Example: ACI/LE105 or ACI/LE117 or ACI/LE1175 or ACI/LE1501

2305 Evergreen Rd. Middleton Industrial Park Middleton, WI 53562

PH: (608) 831-2585 FAX: (608) 831-7407

Multi-Voltage Control Relays

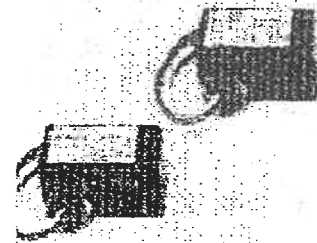
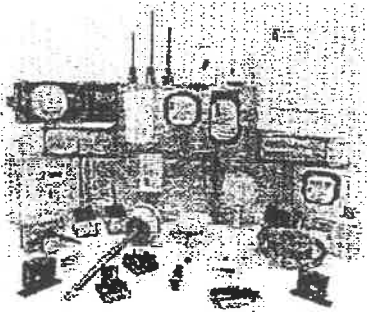

- ACI/LD951**
- ACI/LD96144**
- ACI/LD96152**
- ACI/LD962**
- ACI/LD9651**
- ACI/LD970**
- ACI/LD972**

Product Description

The ACI/LD Series is a line of multi-voltage control relays. These units will not only save labor costs during installation, but they will also allow you to lower your inventory. This unit will replace a number of different one dimensional relays and their sockets. Some of the most common applications for the LD series relays include:

- HVAC or EMS (Energy Management Systems)
- Motors
- Lighting Circuits
- Many other Electrical or Mechanical applications

The LD series control relays meet UL 508 rated and are listed under file # E202892. All of the relays will operate with either AC or DC input voltages and have a red LED to indicate whether the relay is in the N/O or N/C position. Some of the other notable features include an isolated control circuit, electrically noise-free, built-in voltage feedback transient protection, and color coded wires. These units are encased in a UL94-54 rated, NEMA1 plastic enclosure and can be mounted from either the integral mounting flange or thru-bolts. All of the mounting hardware is included with the unit.

All of the LD series control relays come with a two year factory warranty. Please contact ACI for more information regarding any of the control relays.

Product Specifications

Model #.	Description	Contact Rating	Coil Voltage	Operating Temp.
ACI/LD951	(1) DPDT Relay	20A	24 VAC/DC, 18-24 VAC	-40 to 150°F (-40 to 65.5°C)
ACI/LD96144	(1) SPDT Relay	10A	10-30 VAC/DC or 120 VAC	-40 to 150°F (-40 to 65.5°C)
ACI/LD96152	(1) SPDT Relay	10A	10-30 VAC/DC or 120 VAC	-40 to 150°F (-40 to 65.5°C)
ACI/LD962	(1) SPDT Relay	10A	10-30 VAC/DC or 208-277 VAC	-40 to 150°F (-40 to 65.5°C)
ACI/LD9651	(1) SPDT w/HOA Relay	10A	10-30 VAC/DC or 120 VAC	-40 to 150°F (-40 to 65.5°C)
ACI/LD970	(1) SPDT Relay w/HOA, (1) SPDT Relay	10A	10-30 VAC/DC or 120 VAC	-40 to 150°F (-40 to 65.5°C)
ACI/LD972	(2) SPDT Relays	10A	24-30 VAC/DC or 120 VAC	-40 to 150°F (-40 to 65.5°C)

Dimensions

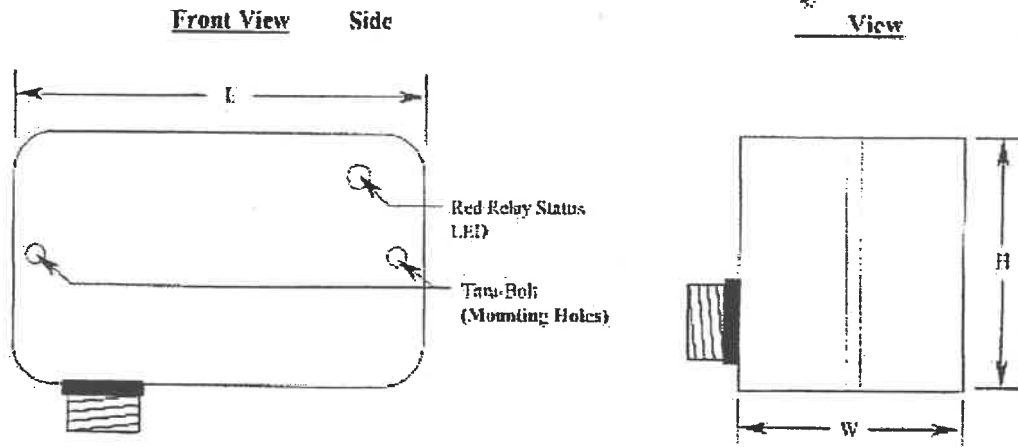

Model #	Length (L)	Width (W)	Height (H)
ACI/LD951	4"	4"	1.8"
ACI/LD96144	1.7"	2.8"	1.5"
ACI/LD96152	1.5"	2.8"	1.5"
ACI/LD962	1.5"	2.8"	1.5"
ACI/LD9651	4"	4"	1.8"
ACI/LD970	4"	4"	1.8"
ACI/LD972	4"	4"	1.8"

Ordering Information

Model #
ACI/ []

↑
LD951 (DPDT Form 2C Relay)
LD96144 (SPDT Form 1C Relay)
LD96152 (SPDT Form 1C Relay)
LD962 (SPDT Form 1C Relay)
LD9651 (SPST w/HOA Form 1A Relay)
LD970 (SPDT w/HOA Form 1C Relay, SPST Relay & Override)
LD972 (SPDT Form 2C Relay)

Close Cross to Functional Devices™ part numbers

*RIB-24P
 *RIB-U1C
 *RIB-H1C
 *RIB-U1C
 *RIB-U15
 *RIB-U25C
 *RIB-U2C

*RIB is a Trademark of Functional Devices

Example: ACI/LD962 or ACI/LD951

2305 Evergreen Rd. Middleton Industrial Park Middleton, WI 53562

PH: (608) 831-2585 FAX: (608) 831-7407

"GO/NO" Current Status Switches

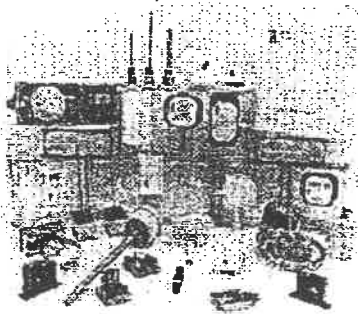

ACI/225
ACI/SC225

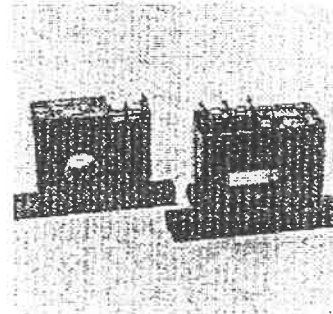

Product Description

The ACI/225 and ACI/SC225 are miniature current sensors designed to replace relays in most applications. The output of the sensor functions as a switch activated by the amount of current sensed. The output is a solid-state relay (more reliable than a mechanical relay) and non-polarity sensitive.

The ACI/225 is the solid-core version while the ACI/SC225 is the split-core version, making it ideal for retrofit applications. Both sensors induce power from the conductor being monitored and require no external power. The Model 225 has a fixed trip point of 1A and the SC225 has a fixed trip point of 1.5A. When the current in the conductor exceeds this threshold, the sensor will be "closed." The sensor will indicate "open" when the current is interrupted or falls to 0A.

These units perform in any application where the amount of current flow is sufficient to indicate the operating status of the sensed load. Some of the most common applications for the 225 and SC225 include:

- Direct Drive Fans
- Pumps - water, condenser, tower, sump, process control
- Heating elements - duct, reheat, oil sump
- Critical motors - compressor, fuel, feedwater
- Lighting circuits - interior, parking
- Ancillary equipment - fume hoods, irrigation pumps, valve status
- OEM - pump controls, no-go interlocks

All 225 and SC225 models come with a five year unconditional factory warranty. Please contact ACI for more information regarding any of these products.

Product Specifications

Amperage Rating	225 - 1 to 250 Amps SC225 - 1.5 to 250 Amps	Trip Point (Setpoint)	225 - Fixed @ 1 Amp SC225 - Fixed @ 1.5 Amp
Output Rating	0.3A Continuous, 135 VAC/VDC	Isolation Voltage	1270 VAC
Response Time	< 120 milliseconds	Hole Size	225 - 0.75" dia., up to 250 MCM cables SC225 - 0.85 dia., up to 350 MCM cables
Frequency Range	6-100 Hz	Operating RH Range	0 to 95%, non-condensing
Operating Temp. Range	-50 to 65°C (-58 to 149°F)	Hysteresis	5% of Setpoint

2305 Evergreen Rd. Middleton Industrial Park Middleton, WI 53562
PH: (608) 831-2585 FAX: (608) 831-7407

Dimensions

All Dimensions are in Inches

ACI/225

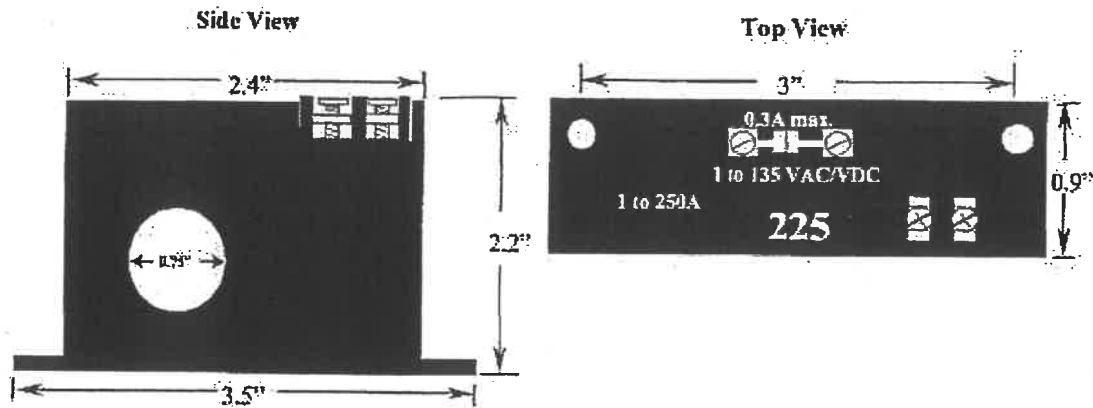

ACI/SC225

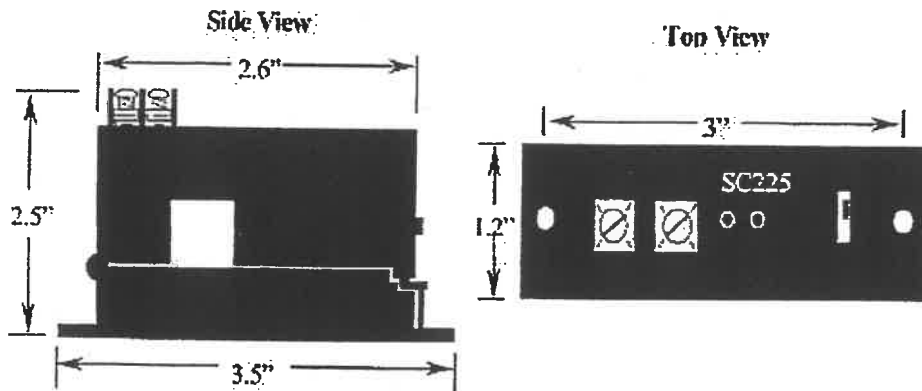

Ordering Information

	Model#	
ACI/		
	↑	
	225	(1 to 250A) - Solid-Core
	SC225	(1.5 to 250A) - Split-Core

Example: ACI/SC225 or ACI/225

WARNING: THIS PRODUCT IS NOT INTENDED FOR LIFE OR SAFETY APPLICATIONS.

2305 Evergreen Rd. Middleton Industrial Park Middleton, WI 53562
 PH: (608) 831-2585 FAX: (608) 831-7407

Adjustable Current Status Switches

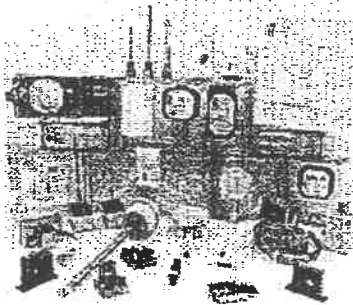

ACI/250
ACI/SC250

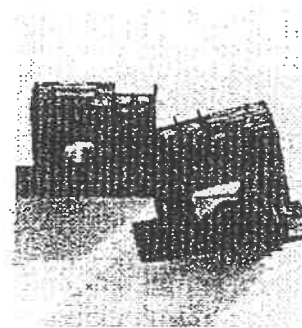

Product Description

The ACI/250 and ACI/SC250 are solid state adjustable current sensors. These current sensors are ideal for providing status information on current using equipment. The 250 series is excellent for new installations, where the conductors run through the housing requiring no cutting. The SC250 series are ideal for retrofits, since their split core can be opened to clamp around the existing conductors. The current sensor is accurate, reliable, easy to install, and requires less service than differential pressure switches, flow switches, and paddle wheels.

The ACI/250 can sense continuous currents from 1 to 150 amps. The sensor does not require any supply voltage, since the power required is induced from the monitored conductor. The output of the sensor is a solid core relay rated to 0.3 Amps at 135 VAC/DC. This sensor also includes an LED indicator that indicates three states: tripped on, current present but below trip point, and current off or below the low end of the range.

The ACI/SC250 can sense continuous currents from 1.5 to 150 amps. The sensor does not require any supply voltage, since the power required is induced from the monitored conductor. The output of the sensor is a solid state relay rated to 0.3 Amps at 135 VAC/DC. This sensor also includes an LED indicator that indicates three states: tripped on, current present but below trip point, and current off or below the low end of the range. All 250 Series current sensors have an unconditional five year factory warranty.

The ACI/250 senses any change in current. A change in current may indicate motor failure, belt loss/slippage, or mechanical failure. Any time one of these events occurs, the current can drop significantly, tripping the sensor, and notifying the controller. Some of the most common monitoring applications include:

- Monitor Fans, Pumps, Heating Elements, & Lighting Circuits
- Critical Motors
- Verify equipment status and Facility power
- Ancillary Equipment

Product Specifications

Amperage Rating ACI/250 ACI/SC250	1 to 150A continuous 1.5 to 150A continuous	Output Rating	0.3A continuous @ 135 VAC/VDC (No Polarity)
Isolation Voltage	1270 VAC, Tested to 5KV	Response time	< 120 milliseconds
Hysteresis (Deadband)	5% of Setpoint	Sensor Hole Size ACI/250	0.75" dia., 250 MCM Cables
Frequency Range	6 - 100 Hz	ACI/SC250	0.85" dia., 350 MCM Cables
Approvals	UL, ULC, CE	Operating Temp. Range	-50 to 65°C (-58 to 149°F)
		Operating RH Range	0-95% RH non-condensing

2305 Evergreen Rd. Middleton Industrial Park Middleton, WI 53562
PH: (608) 831-2585 FAX: (608) 831-7407

Dimensions

All Dimensions are in Inches

ACI/250

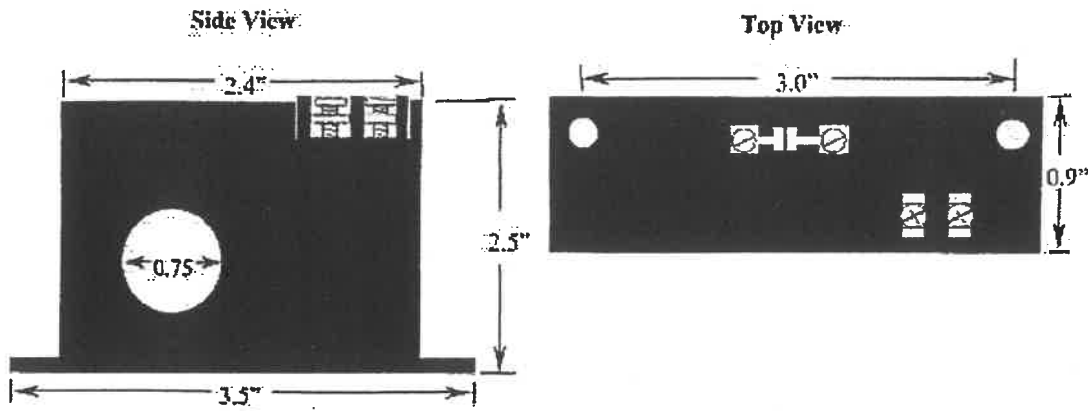

SC250

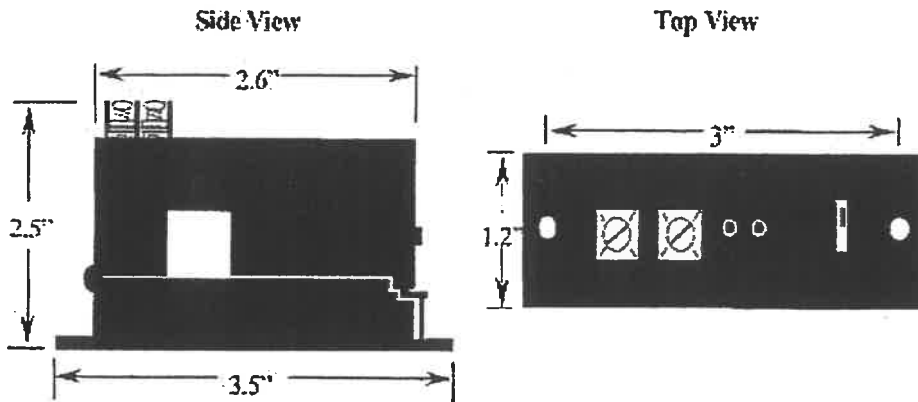

Ordering Information

Model #

ACI/ | |

250 - (1 to 150A) - Solid Core

SC250 - (1.5 to 150A) - Split Core

Example: ACI/250 or ACI/SC250

WARNING: THIS PRODUCT IS NOT INTENDED FOR LIFE OR SAFETY APPLICATIONS

2305 Evergreen Rd. Middleton Industrial Park Middleton, WI 53562

PH: (608) 831-2585 FAX: (608) 831-7407

Low Differential Pressure Transmitters

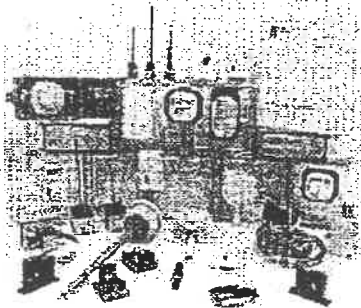

ACI/LP Series

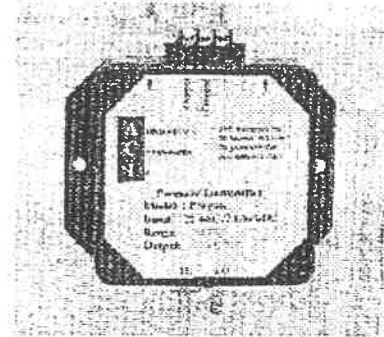

Product Description

The ACI/LP Series transmitters are a low cost alternative to the ACI/DP Series pressure transmitter. The LP Series is a basic 4-20mA transmitter, with uni-directional spans.

These pressure transmitters incorporate a piezoresistive, silicon micromachined sensing element to enable very low pressure measurements. Integrated temperature compensation with offset and span calibration extends performance of these devices without a sacrifice in accuracy.

The transmitters are powered by a +24 to 36 VDC or 24 VAC supply. The electronics provide a two-wire, linear 4-20mA current loop or an optional voltage output. The uni-directional spans range from 0-1" to 0-10" WC.

Factory units are calibrated with a 4-20mA output as standard. If voltage output units are required, they must be ordered as such from the factory.

ACI pressure transmitters may be used in many different applications. They may be used in static pressure applications such as pressure control in rooms or leak detection. Another application is monitoring filter blockage. In combination with a pitot tube or orifice plate, flow can be measured and controlled in ducts. The ACI/LP pressure transmitter uses a durable and proven technology to provide lengthy and stable performance.

All ACI/LP Series transmitters come with a two year factory warranty. Please contact ACI for more information regarding this product.

Product Specifications

Supply Voltage	+24 to 36 VDC / 24 VAC (+/-10%)	Accuracy*	±1.1% F.S.O.
Operating Temperature Range	-13°F to 185°F (-25 to 85°C)	Repeatability	±0.3% F.S.O. nominal
Compensated Temperature Range	+32°F to 122°F (0 to 50°C)	Full Scale Shift (0°C to 50°C)	±2.0% F.S.O.
Output	2-wire, 4 to 20 mA or 3-wire, 1-5 or 2-10 VDC	Media	Dry air or inert non-conductive gases
Max Current Draw	23mA Max Draw		

* Accuracy includes linearity, hysteresis and repeatability

2305 Evergreen Rd. Middleton Industrial Park Middleton, WI 53562
PH: (608) 831-2585 FAX: (608) 831-7407

Dimensions

All Dimensions are in Inches

Top View

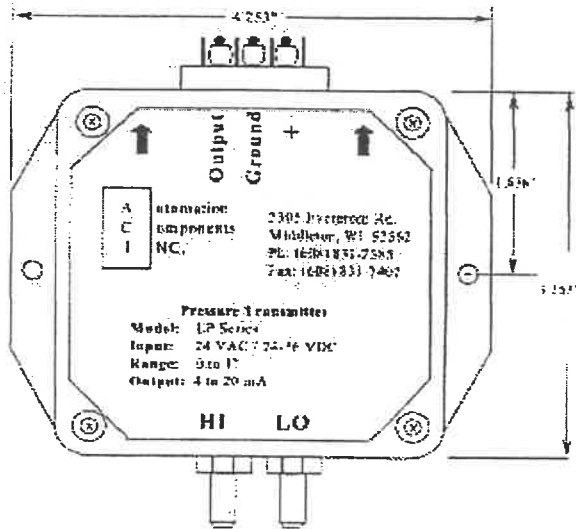

Side View

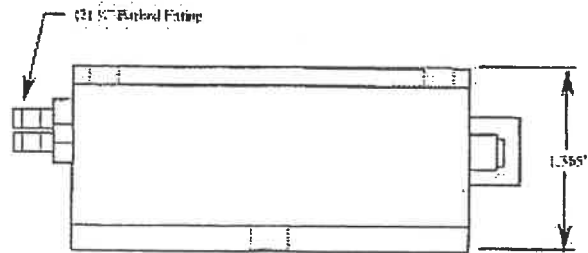

End View

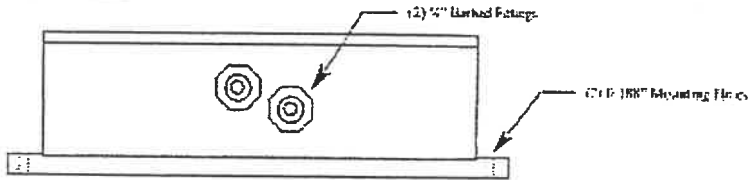

Ordering Information

A/LP	- []	Output	- []
	↑	↑	
	(1) 0 to 1"	(5) 1 to 5 VDC	
	(2) 0 to 2"	(10) 2 to 10 VDC	
	(3) 0 to 3"	(20) 4 to 20 mA	
	(5) 0 to 5"		
	(10) 0 to 10"		
	Please Specify		

Example: A/LP-(1)-20 or A/LP-(0-5")-5 or A/LP-(0-6")-20

2305 Evergreen Rd. Middleton Industrial Park Middleton, WI 53562
PH: (608) 831-2585 FAX: (608) 831-7407

Differential Pressure Switch w/ Manual Reset

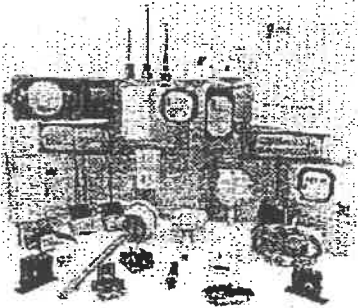

ACI/AFS-460



Product Description

The ACI/AFS-460 series differential pressure switches are general purpose proving switches designed to require a manual operator reset following actuation. These pressure switches can be used to sense either positive, negative, or differential air pressure in HVAC and Energy Management applications which require operator interface.

The AFS-460 has an input operating range of 0.40" to 12.0" w.c. with an adjustable setpoint range of 0.40" +/- 0.06" to 12" of w.c.. Each unit contains a diaphragm, calibration spring, and a snap-acting SPST-NC (Manual Reset) switch.

The sampling connections are located on each side of the diaphragm. They will accept a 0.25" O.D. rigid metallic tubing via the integral compression ferrule and nut. The enclosure cover guards against accidental contact with the "live switch" terminal screws and the setpoint adjustment screw. The AFS-460 also contains a 1/2" conduit knockout in the cover of the enclosure.

Other options may be available upon request. All of the AFS-460 Series differential pressure switches come with a two year factory warranty. Please contact ACI for more information regarding the ACI/AFS-460 differential pressure switches.

Product Specifications

Input Pressure Range	AFS-460 (0.40" to 12" w.c.)	Measured Media	Air or combustion by-products that will not degrade silicon.
Electrical Rating	@60 Hz, 15 Amp 125, 250, or 277 VAC ¼ hp 125 VAC, ½ hp 250 VAC ½ Amp 125 VDC ¼ Amp 250 VDC	Operating Temp. Range	-40 to 180°F (-40 to 82.2°C)
Output	SPST-NC contacts (Manual Reset)	Mounting Direction	Any Vertical Plane
Maximum Pressure	0.5 psi	Approval	UL ; CSA
Switch Differential	0.01" w.c. minimum setpoint to 0.8" w.c. at maximum setpoint	Shipping weight	1.2 lbs

2305 Evergreen Rd. Middleton Industrial Park Middleton, WI 53562

PH: (608) 831-2585 FAX: (608) 831-7407

Dimensions

AFS-460

Side View

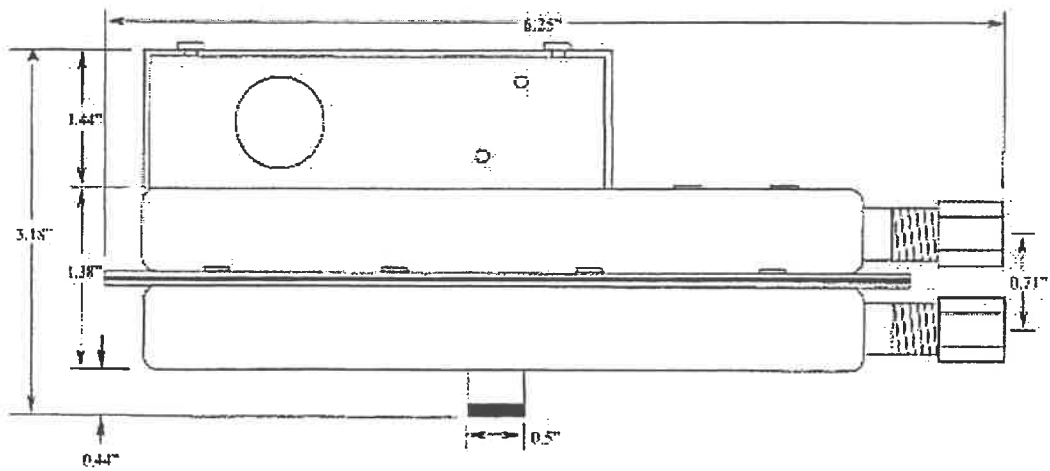

End View

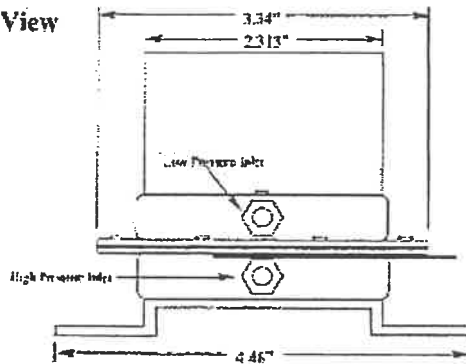

ACI/VPT

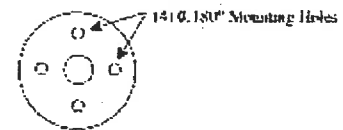
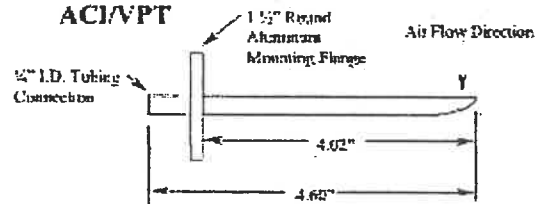

ACI/SPT

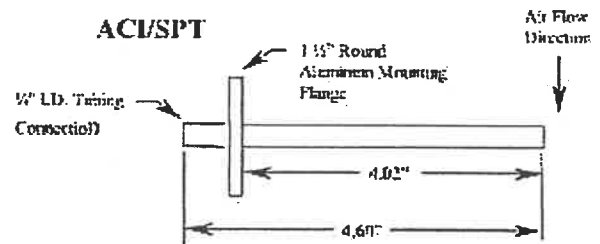

Ordering Information

ACI/AFS-460 and ^{Pitot Tube} ACI/VPT - Velocity Pressure Pitot Tube (Optional)
ACI/SPT - Static Pressure Pitot Tube (Optional)

Example: ACI/AFS-460 or ACI/VPT or ACI/SPT

2305 Evergreen Rd. Middleton Industrial Park Middleton, WI 53562

PH: (608) 831-2585 FAX: (608) 831-7407

Differential Pressure Switches w/Auto Reset

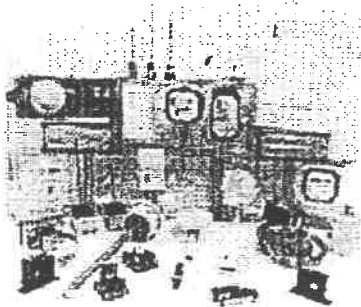

ACI/AFS-222

ACI/AFS-262

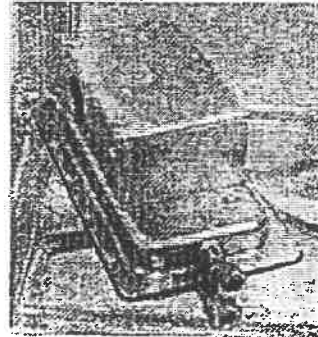

Product Description

The ACI/AFS Series differential pressure switches are general purpose proving switches designed for both HVAC and Energy Management applications. These pressure switches can be used to sense either positive, negative, or differential air pressure.

The ACI/AFS-222 has a field adjustable operating range of 0.07" to 12.0" w.c. The AFS-222 has a field adjustable setpoint range of 0.05" to 0.02" to 12" w.c. with a field adjustable release range of 0.04" to 11.2" of w.c.. Each unit contains a diaphragm, calibration spring, and a snap-acting SPDT switch.

The ACI/AFS-262 has a field adjustable operating range of 0.07" to 2.0" w.c. It also has a setpoint range of 0.05" to 0.02" to 2" w.c. with a field adjustable "release range" of 0.04" to 1.9" w.c.

Each unit contains a diaphragm, calibration spring, and a snap-acting SPDT switch.

The sampling connections are located on each side of the diaphragm. Both the AFS-222 and AFS-262 will accept a 0.25" O.D. rigid metallic tubing via the integral compression ferrule and nut. The enclosure cover guards against accidental contact with the live switch terminal screws and the setpoint adjusting screw. The AFS-222 also contains a 1.2" conduit knockout in the cover of the enclosure.

Other options may be available upon request. All of the ACI/AFS Series differential pressure switches come with a two year factory warranty. Please contact ACI for more information regarding any of the ACI/AFS Series differential pressure switches.

Product Specifications

Input Pressure Range	AFS-222 (0.07" to 12" w.c.) AFS-262 (0.07" to 2" w.c.)	Measured Media	Air, or combustion by-products that will not degrade silicon
Electrical Rating	300 VA pilot duty @ 115 to 277 VAC 15 amps non-inductive to 277 VAC, 60 Hz	Operating Temp. Range	-40 to 180°F (-40 to 82°C)
Output	1 set SPDT Contacts	Mounting Direction	Any Vertical Plane
Maximum Pressure	0.5 psi	Approval	UL, FM, CSA, CE
Switch Differential	increasing from 0.01" w.c. at Minimum	Shipping Weight	1.2 lbs
Setpoint	+0.08" w.c. @ Maximum Setpoint		

2305 Evergreen Rd. Middleton Industrial Park Middleton, WI 53562

PH: (608) 831-2585 FAX: (608) 831-7407

Tab 2



AUTOMATED TEMPERATURE CONTROLS SEQUENCE OF OPERATION FOR PEWAUKEE
PUBLIC LIBRARY

AHU-1 *VARIABLE AIR VOLUME AHU WITH SUPPLY AND SPACE TEMPERATURE RESET*

1. OCCUPIED MODE

THE AUTOMATED TEMPERATURE CONTROL SYSTEM (ATCS) WILL SEQUENCE, MODULATE OUTSIDE AIR, EXHAUST AIR AND RETURN AIR DAMPERS, HOT WATER COIL VALVE, PUMP P-5, DIRECT EXPANSION COOLING, SUPPLY FAN, RETURN FAN TO MAINTAIN DISCHARGE AIR SETPOINT.

SUPPLY FAN AND RETURN FAN WILL OPERATE CONTINUOUSLY WHEN AHU IS IN OCCUPIED, OR MORNING WARMUP MODE. VARIABLE FREQUENCY DRIVE WILL MODULATE TO MAINTAIN DUCT STATIC SETPOINT (1"WC) adjustable. OUTSIDE AIR DAMPER WILL TRAC WITH VARIABLE FREQUENCY DRIVE TO MAINTAIN MINIMUM AIR REQUIREMENTS. THE OUTSIDE AIR AND RETURN AIR DAMPERS WILL MODULATE TO MINIMUM AIR POSITION. HOT WATER VALVE WILL MODULATE TO MAINTAIN SETPOINT. IF A FREEZE CONDITION IS DETECTED THE SUPPLY AND RETURN FAN WILL SHUT DOWN, OUTSIDE, EXHAUST AIR DAMPER WILL CLOSE AND RETURN AIR DAMPERS WILL OPEN. WHEN SMOKE IS PRESENT THE DETECTOR WILL SHUT DOWN THE FAN, AND DISABLE THE AHU.

DX COOLING WILL BE INTERLOCKED WITH SUPPLY AND RETURN FANS. CONDENSING UNIT WILL BE CYCLED TO MAINTAIN DISCHARGE AIR SETPOINT. DURING DX COOLING HOT WATER VALVE WILL BE CLOSE. TIME DELAYS BETWEEN STAGES AND SHORTCYCLE DELAY WILL PROTECT COMPRESSORS. IF OUTSIDE AIR TEMPERATURE IS BELOW CHANGEOVER SETPOINT CONDENSING UNIT WILL BE LOCKED OUT.

WHEN OUTSIDE AIR TEMPERATURE IS LESS THAN THE CHANGEOVER SETPOINT (55deg. F.) adjustable THE OUTSIDE AIR DAMPER AND RETURN AIR DAMPERS WILL MODULATE FROM MINIMUM TO MAXIMUM POSITION TO MAINTAIN DISCHARGE AIR SETPOINT. A MIXED AIR TEMPERATURE SETPOINT WILL OVERRIDE DAMPER OPERATION TO PROTECT HOT WATER COILS.

DUCT HIGH LIMIT PRESSURE SENSOR WILL STOP THE SUPPLY AND RETURN FAN MOTOR IF PRESSURE IS GREATER THAN (5" WC)

SPACE STATIC PRESSURE SENSOR WILL MAINTAIN SPACE STATIC SETPOINT OF (.01"WC) adjustable, VIA RELIEF FAN AND RETURN AND EXHAUST AIR DAMPER POSITION

2. UNOCCUPIED MODE

AHU WILL CYCLE INTERMITTENTLY TO MAINTAIN UNOCCUPIED SETPOINTS. THE OUTSIDE, EXHAUST AIR DAMPERS WILL CLOSE WHEN UNIT CALLS FOR HEAT. WHENEVER THE FAN IS OFF THE HOT WATER COIL VALVE WILL OPEN.

3. AUTOMATED TEMPERATURE CONTROL SYSTEM (ATCS) WILL MONITOR AND REPORT THE FOLLOWING POINTS TO DIRECT DIGITAL CONTROL (DDC) CONTROLLER

- a. DISCHARGE AIR TEMP
- b. MIXED AIR TEMP
- c. RETURN AIR TEMP
- d. RETURN AIR FLOW, CFM

- e. SUPPLY AIR FLOW, CFM
- f. BLDG. STATIC PSI
- g. DUCT PRESSURE, "WC
- h. DUCT HIGH LIMIT STATUS
- i. SUPPLY FAN STATUS
- j. RETURN FAN STATUS
- k. FREEZE STAT STATUS
- l. DUCT SMOKE STATUS
- m. FILTER STATUS
- n. DAMPER OUTPUTS, %
- o. HOT WATER VALVE OUTPUT, %
- p. DX COOL OUTPUT, STAGES

HUMIDIFIER

- 4. SPACE RELATIVE HUMIDITY SENSOR WILL MAINTAIN SETPOINT OF (40% RH) adjustable. HUMIDIFIER WILL BE INTERLOCKED WITH SUPPLY AND RETURN FANS. DISCHARGE AIR LIMIT OF 80% WILL CONTROL HUMIDIFIER DURING OPERATION
- 5. AUTOMATED TEMPERATURE CONTROL SYSTEM (ATCS) WILL MONITOR AND REPORT THE FOLLOWING POINTS TO DIRECT DIGITAL CONTROL (DDC) CONTROLLER
 - a. SPACE % RH
 - b. SUPPLY % RH
 - c. HUMIDIFIER STATUS
 - d. HUMIDIFIER % OUTPUT

HOT WATER SYSTEM

- 6. THE HOT WATER SYSTEM CONSISTS OF BOILER 1, BOILER 2, PUMPS 1, 2, INLINE PUMPS 1, 2. HOT WATER SYSTEM WILL BE ENABLED WHEN THE OUTSIDE AIR TEMPERATURE IS BELOW (70deg. F) adjustable. BOILERS AND PUMPS P-1, P-2 WILL BE CONTROLLED BY A LEAD LAG SEQUENCE. UPON LEAD PUMP FAILURE, LAG PUMP WILL START AND ALARM WILL BE GENERATED. BOILER INLINE PUMPS WILL CYCLE WITH BOILERS AND CONTINUE TO RUN AFTER BOILER CYCLES OFF, FOR (10min) TO REJECT HEAT FROM BOILER. THE PRIMARY HOT WATER RETURNS TEMPERATURE WILL BE RESET OFF OUTSIDE AIR TEMPERATURE.

OUTSIDE AIR

0 deg. F
70 deg. F

HOT WATER RETURN

180 deg. F
140 deg. F

- 7. AUTOMATED TEMPERATURE CONTROL SYSTEM (ATCS) WILL MONITOR AND REPORT THE FOLLOWING POINTS TO DIRECT DIGITAL CONTROL (DDC) CONTROLLER
 - a. HOT WATER SUPPLY TEMP
 - b. HOT WATER RETURN TEMP
 - c. OUTSIDE AIR TEMPERATURE
 - d. OUTSIDE AIR % RH
 - e. PUMP STATUS, 4 PC
 - f. BOILER STATUS, 2 PC
 - g. BOILER ALARM, 2 PC

VAV'S VARIABLE AIR VOLUME BOX WITH HOT WATER REHEAT COILS

8. OCCUPIED MODE

A CALL FOR COOLING WILL MODULATE AIR DAMPER TO MAXIMUM CFM'S. IF HEATING IS REQUIRED THE HOT WATER VAVLE WILL MODULATE OPEN AND AIR DAMPER WILL MAINTAIN MAXIMUM HEATING CFM'S. WHEN SYSTEM IS IN SUMMER MODE BOXES WILL BE ALLOWED TO MODULATE DOWN TO 30% OF MAXIMUM. IF IN WINTER MODE, BOXES WILL BE ALLOWED TO MODULATE DOWN TO HEATING MINIMUM VALUE. WHEN VAV BOX SERVES AN AREA WHICH HAS SUPPLEMENTRY HEAT, SUP. HEAT WILL BE PRIMARY HEAT IN SEQEUNCE.

9. UNOCCUPIED MODE

AIR DAMPER WILL MODULATE CLOSED. WHEN A HEAT / COOL REQUESTS ARE ABOVE MINIMUM NUMBER OF CALLERS THE AHU FAN WILL BE CYCLED ON AND THE VAV BOXES WILL MAINTAIN SPACE TEMPERATURES AT UNOCCUPIED SETPOINTS. ONCE MINIMUM NUMBER OF CALLERS IS SATISFIED AHU WILL CYCLE OFF. IF HOT WATER SYSTEM IS NOT ENABLED AHU WILL NOT CYCLE ON TO HEAT TO UNOCCUPIED TEMPERATURES.

10. AUTOMATED TEMPERATURE CONTROL SYSTEM (ATCS) WILL MONITOR AND REPORT THE FOLLOWING POINTS TO DIRECT DIGITAL CONTROL (DDC) CONTROLLER

- a. SPACE TEMP
- b. O/R STATUS
- c. CFM
- d. DAMPER POSITION
- e. HEAT % OUTPUT
- f. ALARM STATUS

UH'S *HOT WATER UNIT HEATERS*

11. THE UNIT HEATER WILL OPERATE IN A STAND ALONE MODE. A WALL MOUNTED THERMOSTAT WILL CYCLE THE UNITS FAN AND HOT WATER VALVE TO MAINTAIN SPACE SETPOINT.

CAB'S *CABINET UNIT HEATERS*

12. THE UNIT HEATER WILL OPERATE IN A STAND ALONE MODE. A WALL MOUNTED THERMOSTAT WILL CYCLE THE UNITS HOT WATER VALVE TO MAINTAIN SPACE SETPOINT. THE UNITS FAN WILL CYCLE ON WHEN A RISE IN DISCHARGE AIR TEMPERATURE IS SENSED.

CONVECTORS

13. THE CONECTOR WILL OPERATE IN A STAND ALONE MODE. A WALL MOUNTED THERMOSTAT WILL CYCLE THE HOT WATER VAVLE TO MAINTAIN SPACE SETPOINT.

FIN PIPE RADIATION

14. THE FIN PIPE RADIATION WILL BE CONTROLLED VIA VAV CONTROLLER AS SUPPLEMENTAL HEAT.
- 15.

PRV'S ROOF EXHAUST FANS

16. PRV-1 WILL CYCLE ON STAND ALONE LINE VOLTAGE THERMOSTAT
17. PRV-2, 3 WILL CYCLE ON WHEN AHU-1 IS IN OCCUPIED MODE

OPERATOR WORK STATION

18. OWS WITH PENTIUM PROCESSOR, CLOCK AND CALANDER NOT AFFECTED BY POWER OUTAGE FOR 30 DAYS.
19. OWS SHALL BE PROVIDED WITH INTERNAL MODEM, COLOR MONITOR, KEYBOARD AND PRINTER.
20. FURNISH AND INSTALL DEDICATED TELEPHONE LINE AND ALL UTILITY COSTS FOR ONE YEAR.

Tab 3

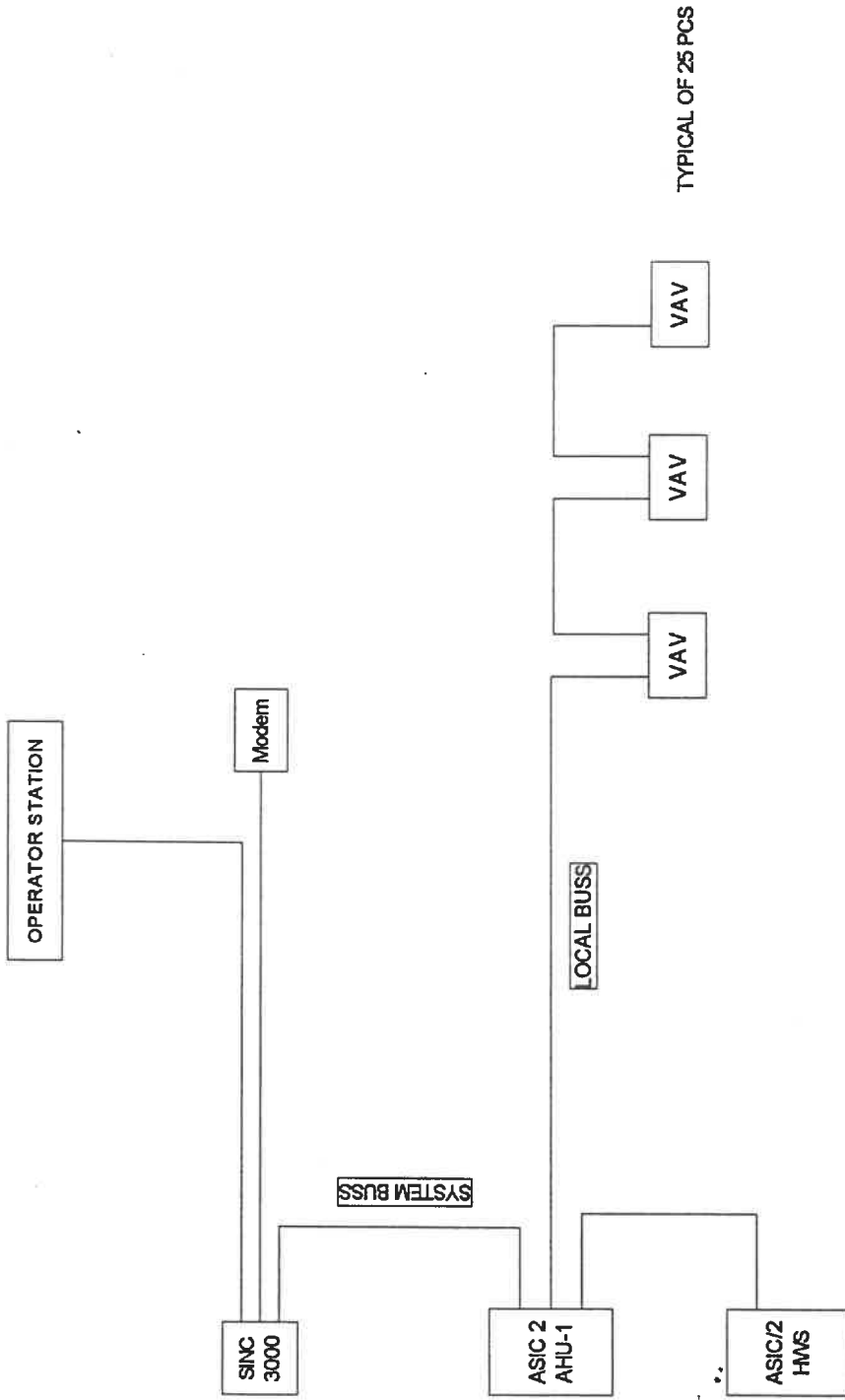

PEWAUKEE PUBLIC LIBRARY	DRAWN BY: C W	DATE: 4/1/05
	ENGR: HARWOOD ENG.	REVISED:
	SYSTEM AND LOCAL BUSS	PAGE: 1

J & H HEATING, INC.
 1220 MINERAL SPRINGS DR
 PORT WASHINGTON, WI 53044
 P# 262-264-5588
 F# 262-264-3388





QTY.	POINT	DESCRIPTION	PART #
2	INPUT	ASI, TEMP SENSOR	TSD-12
1	INPUT	ABI, TEMP SENSOR	TSA-12
1	INPUT	ACI, PRESSURE TRANSMITTER	MLP-5-5
2	INPUT	ACI, HUMIDITY SENSOR, DUCT	
1	INPUT	ACI, HUMIDITY SENSOR, SPACE	
1	INPUT	ACI, SPACE TEMP	
1	INPUT	ACI, FREEZE STAT	FS-2
1	INPUT	KELE, DP SWITCH	RH-3
2	INPUT	AIR FLOW STATION	
4	INPUT	ACI, CURRENT SENSOR	ACI-260
1	INPUT	KELE, DUCT HIGH % LIMIT	
1	INPUT	DUCT SMOKE	
4	OUTPUT	ACI, RELAY	ACI-LD98144
2	OUTPUT	ACI, RELAY, HIGH AMP	
1	OUTPUT	KELE, RELAY BLOCK	MR-800/T
3	OUTPUT	BELIMO ACTUATOR	AF24SR

J & H HEATING, INC.
 1220 MINERAL SPRINGS DR
 FORT WASHINGTON, WI 53044
 PH: 262-284-5599
 FX: 262-284-3389

DATE: 4/105
 REVISIONS:
 PAGE: 2

PEWAUKEE PUBLIC LIBRARY

DRAWN BY: C.W
 ENGR: HARWOOD ENG.
 AHU-1

DATE: 4/105
 REVISIONS:
 PAGE: 2

RETURN AIR TEMP	IN-1
	COM
MIXED AIR TEMP	IN-2
	COM
DISCHARGE AIR TEMP	IN-3
	COM
DUCT STATIC PSI	IN-4
	COM
DUCT HIGH LIMIT PSI	IN-5
	COM
SMOKE DUCT	IN-6
	COM
FREEZE	IN-7
	COM
FILTER DP SWITCH	IN-8
	COM
RETURN AIR FLOW STATION	IN-9
	COM
SUPPLY AIR FLOW STATION	IN-10
	COM
SUPPLY % RH	IN-11
	COM
SPACE % RH	IN-12
	COM
	IN-13
	COM
	IN-14
	COM
	IN-15
	COM
	IN-16
	COM
A SF STATUS	
B RF STATUS	
C FAN STATUS	
D HUMIDIFIER STATUS	

SUPPLY FAN	BO-1A
	BO-1B
RETURN FAN	BO-2A
	BO-2B
P-5 START	BO-3A
	BO-3B
HUMIDIFIER	BO-4A
	BO-4B
COOL 1	BO-5A
	BO-5B
COOL 2	BO-6A
	BO-6B
COOL 3	BO-7A
	BO-7B
COOL 4	BO-8A
	BO-8B
LLSV-1	BO-9A
	BO-9B
LLSV-2	BO-10A
	BO-10B
PRV-2	BO-11A
	BO-11B
PRV-3	BO-12A
	BO-12B

BO-13	LED-1
BO-14	LED-2
BO-15	LED-3
BO-16	LED-4

SUPPLY FAN VFD	AO-1
	COM
RETURN FAN VFD	AO-2
	COM
HOT WATER VALVE	AO-3
	COM
RETURN AIR DAMPER	AO-4
	COM
OUTSIDE AIR DAMPER	AO-5
	COM
EXHAUST AIR DAMPER	AO-6
	COM
HUMIDIFIER	AO-7
	COM
	AO-8
	COM

24 VAC HOT	J6-1
GROUND	J6-2
COMMON	J6-3

COMMON	TB2-3
SYSTEM BUS -	TB2-2
SYSTEM BUS +	TB2-1

COMMON	TB1-3
LOCAL BUS -	TB1-2
LOCAL BUS +	TB1-1

J & H HEATING, INC.
 1220 MINERAL SPRINGS DR
 PORT WASHINGTON, WI 53044
 P# 262-284-5589
 F# 262-284-3388



PEWAUKEE PUBLIC LIBRARY

DRAWN BY: C W
 ENGR: HARWOOD ENG.
 AHU-1 POINT LIST

DATE 4/1/05
 REVISED:
 PAGE: 3

QTY.	POINT	DESCRIPTION	PART #
1	INPUT	ASI, OUTSIDE AIR TEMP	T SO
1	INPUT	ASI, OUTSIDE AIR % RH	
2	INPUT	ACI, IMMERSION TEMP	ACI=3K-1-2.5, ACI-2.5 WELL
4	INPUT	ACI, CURRENT RELAY	ACI/250
8	INPUT, OUTPUT	ACI, RELAY	ACI-LD66144

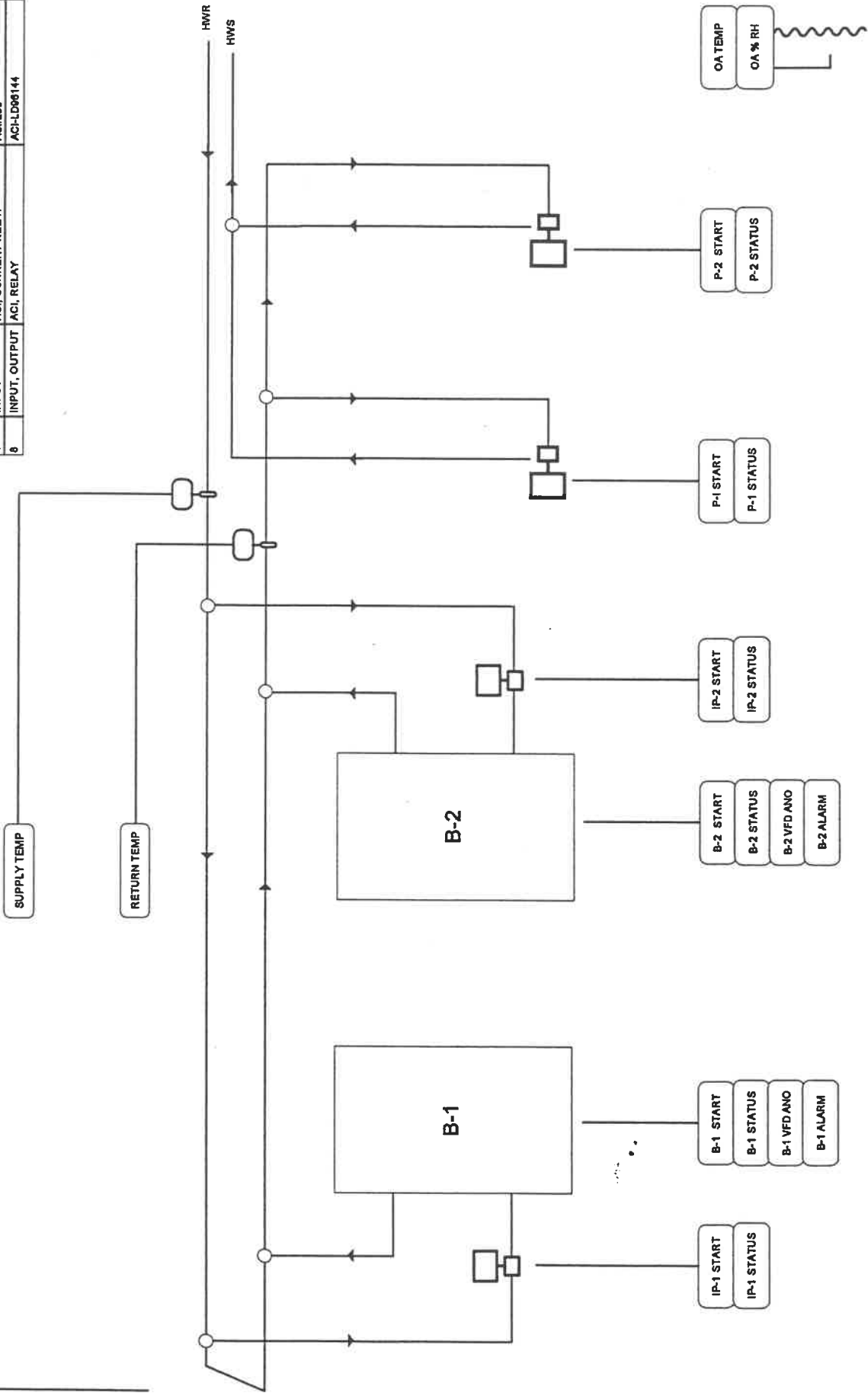

 J & H Heating INCORPORATED	J & H HEATING, INC. 1220 MINERAL SPRINGS DR PORT WASHINGTON, WI 53044 PH 262-294-5589 FX 262-294-3389	DRAWN BY: C W ENGR: HARWOOD ENG. BOILERS AND PUMPS	DATE: 4/1/05 REVISED: PAGE: 4
	PEWAUKEE PUBLIC LIBRARY		

OUTSIDE AIR TEMP	IN-1
	COM
OUTSIDE AIR % RH	IN-2
	COM
HOT WATER SUPPLY	IN-3
	COM
HOT WATER RETURN	IN-4
	COM
B-1 FSG ALARM	IN-5
	COM
B-2 FSG ALARM	IN-6
	COM
	IN-7
	COM
	IN-8
	COM
	IN-9
	COM
	IN-10
	COM
	IN-11
	COM
	IN-12
	COM
	IN-13
	COM
	IN-14
	COM
	IN-15
	COM
	IN-16
	COM

A P-1 STATUS
 B P-2 STATUS
 C IP-1 STATUS
 D IP-2 STATUS

P-1	BO-1A
	BO-1B
P-2	BO-2A
	BO-2B
P-1	BO-3A
	BO-3B
P-2	BO-4A
	BO-4B
B-1	BO-5A
	BO-5B
B-2	BO-6A
	BO-6B
	BO-7A
	BO-7B
	BO-8A
	BO-8B
	BO-9A
	BO-9B
	BO-10A
	BO-10B
	BO-11A
	BO-11B
	BO-12A
	BO-12B

BO-13	LED-1
BO-14	LED-2
BO-15	LED-3
BO-16	LED-4

B-1 VFD	AO-1
	COM
B-2 VFD	AO-2
	COM
	AO-3
	COM
	AO-4
	COM
	AO-5
	COM
	AO-6
	COM
	AO-7
	COM
	AO-8
	COM

24 VAC HOT	J6-1
GROUND	J6-2
COMMAN	J6-3

COMMON	TB2-3
SYSTEM BUS -	TB2-2
SYSTEM BUS +	TB2-1

COMMON	TB1-3
LOCAL BUS -	TB1-2
LOCAL BUS +	TB1-1

J & H HEATING, INC.
 1220 MINERAL SPRINGS DR
 FORT WASHINGTON, WI 53044
 P# 262-284-5599
 F# 262-284-3389



PEWAUKEE PUBLIC LIBRARY

DRAWN BY: C W
 ENGR: HARWOOD ENG.
 HOT WATER SYSTEM POINT LIST

DATE 4/1/05
 REVISED:
 PAGE: 5

QTY.	POINT	DESCRIPTION	PART #
25	CONTROLLER	ASIC 6000	ASIC/J 6000
25	INPUT	ACI, T-STAT	ASI-3K-R50
25	INPUT	ACI, TEMP SENSOR	ASI-3K-DD4*
25	POWER	KELE, TRANSFORMER	TR150VA001
11	OUTPUT	AUX HEAT RELAY	

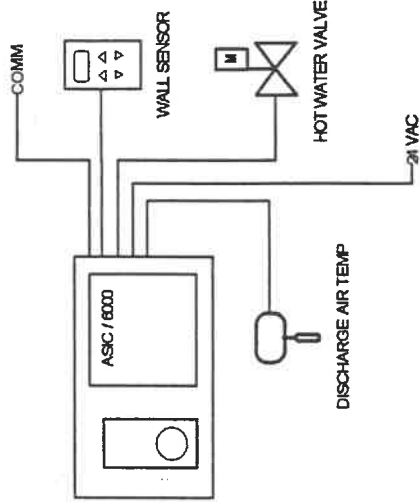

VAV WITH HOT WATER HEAT, TYP. OF 12 FC

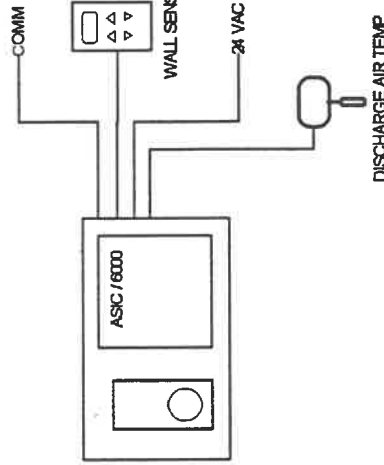

VAV COOLING ONLY, TYP. OF 2 FC

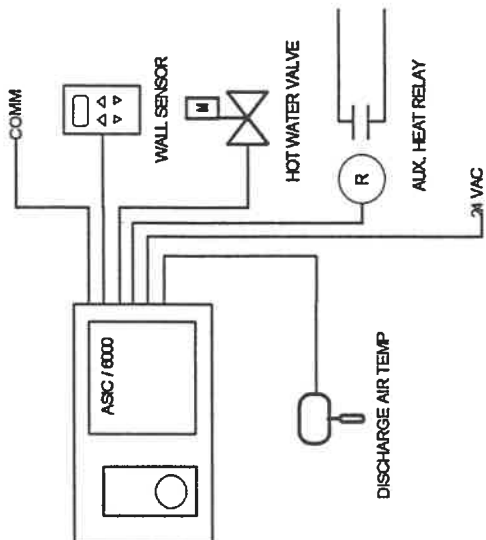

VAV WITH HOT WATER HEAT & AUX HEAT, TYP. OF 11 FC

 J & H Heating INCORPORATED	PEWAUKEE PUBLIC LIBRARY	DRAWN BY: C W ENGR: HARWOOD ENG. VAV'S	DATE: 4/1/05 REVISED: PAGE: 6
	J & H HEATING, INC. 1120 MINERAL SPRINGS DR FORT WASHINGTON, WI 53044 PH: 262-284-5589 FX: 262-284-3389		
	PEWAUKEE PUBLIC LIBRARY		

CITY.	POINT	DESCRIPTION	PART #
14	STAT	UNIVERSAL TYPE	
18	OUTPUT	ACT, HIGH AMP RELAY	ACH-LD851

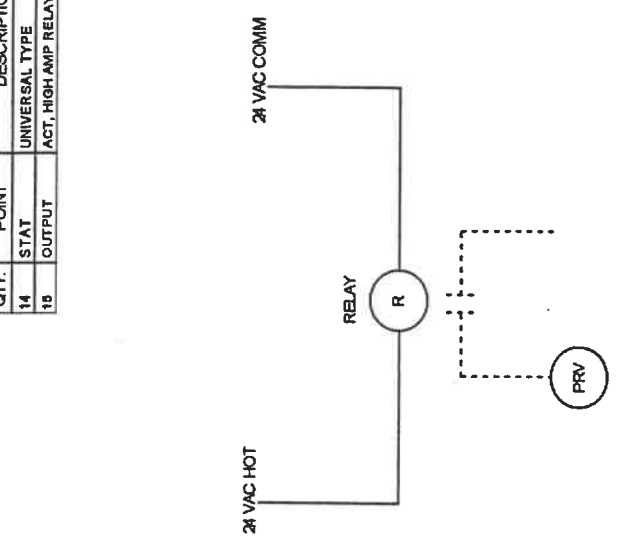

PRV-2, 3 DETAIL

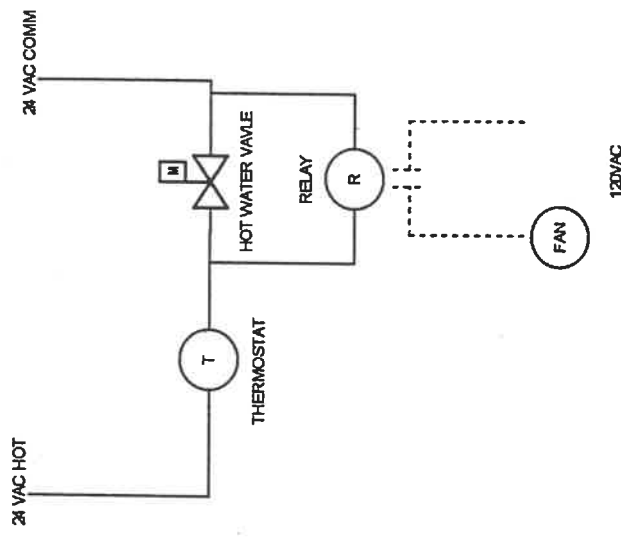

CABINET HEATER DETAIL, TYP OF 5 PC

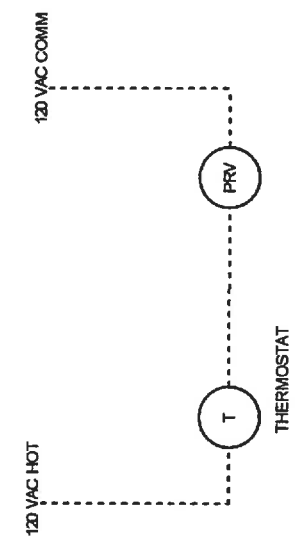

PRV-1 DETAIL

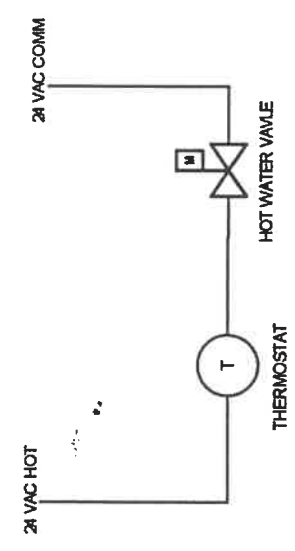

CONNECTOR DETAIL, TYP OF 6 PC

	PEWAUKEE PUBLIC LIBRARY		DRAWN BY: C.W. ENGR: HARWOOD ENG. CONV., CAB HTRS., PRVS	DATE: 4/1/05 REVISED: PAGE: 7
	J & H HEATING, INC. 1220 MINERAL SPRINGS DR FORT WASHINGTON, WI 53044 PH: 262-284-6669 FX: 262-284-3389			
	IN CORPORATION			

Tab 4



J & H HEATING, INC.
1220 MINERAL SPRINGS DR
FORT WASHINGTON, WI 53044
PH 262-284-6589
FX 262-284-3389

PEWAUKEE PUBLIC LIBRARY

DRAWN BY: C W

ENGR: HARWOOD ENG.

LOGIC DIAG.

DATE: 4/1/05

REVISED:

PAGE: 1

Tab 5

PROJECT: Pewaukee Library



SYSTEM	SERVICE	QTY	L. SIZE	GPM	CV	STYLE	V. SIZE	ACTION	MANUF.	PART#	FAIL POS.
AHU-1	HW COIL	1	2"	20	15	3-WAY	1 1/4"	MOD.	BELIMO	B330-NF24SR	OPEN
V-1	HW COIL	1	3/4"	3.3	1.9	3-WAY	1/2"	FLT	BELIMO	B311-LR24	LAST POS.
V-2	HW COIL	1	3/4"	1.5	0.9	3-WAY	1/2"	FLT	BELIMO	B309-LR24	LAST POS.
V-3	HW COIL	1	3/4"	0.5	0.3	3-WAY	1/2"	FLT	BELIMO	B309-LR24	LAST POS.
V-4	HW COIL	1	3/4"	0.8	0.5	2-WAY	1/2"	FLT	BELIMO	B209-LR24	LAST POS.
V-5	HW COIL	1	3/4"	1	0.6	3-WAY	1/2"	FLT	BELIMO	B309-LR24	LAST POS.
V-6	HW COIL	1	3/4"	0.5	0.3	2-WAY	1/2"	FLT	BELIMO	B209-LR24	LAST POS.
V-7	HW COIL	1	3/4"	1	0.6	2-WAY	1/2"	FLT	BELIMO	B209-LR24	LAST POS.
V-8	HW COIL	1	3/4"	1.6	1	3-WAY	1/2"	FLT	BELIMO	B309-LR24	LAST POS.
V-11	HW COIL	1	3/4"	0.6	0.4	2-WAY	1/2"	FLT	BELIMO	B209-LR24	LAST POS.
V-12	HW COIL	1	3/4"	3	1.8	3-WAY	1/2"	FLT	BELIMO	B311-LR24	LAST POS.
V-13	HW COIL	1	3/4"	1.5	0.9	3-WAY	1/2"	FLT	BELIMO	B309-LR24	LAST POS.
V-14	HW COIL	1	3/4"	1.5	0.9	3-WAY	1/2"	FLT	BELIMO	B309-LR24	LAST POS.
V-15	HW COIL	1	3/4"	2.8	1.9	3-WAY	1/2"	FLT	BELIMO	B311-LR24	LAST POS.
V-16	HW COIL	1	3/4"	1.3	0.8	2-WAY	1/2"	FLT	BELIMO	B211-LR24	LAST POS.
V-17	HW COIL	1	3/4"	0.9	0.6	2-WAY	1/2"	FLT	BELIMO	B209-LR24	LAST POS.
V-18	HW COIL	1	3/4"	1.5	0.9	3-WAY	1/2"	FLT	BELIMO	B309-LR24	LAST POS.
V-19	HW COIL	1	3/4"	0.6	0.4	2-WAY	1/2"	FLT	BELIMO	B209-LR24	LAST POS.
V-20	HW COIL	1	1"	3.4	2	3-WAY	1/2"	FLT	BELIMO	B311-LR24	LAST POS.
V-21	HW COIL	1	3/4"	3.2	1.9	3-WAY	1/2"	FLT	BELIMO	B311-LR24	LAST POS.
V-22	HW COIL	1	3/4"	1.1	0.8	2-WAY	1/2"	FLT	BELIMO	B209-LR24	LAST POS.
V-23	HW COIL	1	3/4"	1.3	0.8	3-WAY	1/2"	FLT	BELIMO	B309-LR24	LAST POS.
V-24	HW COIL	1	3/4"	2.4	1.9	3-WAY	1/2"	FLT	BELIMO	B311-LR24	LAST POS.
V-25	HW COIL	1	3/4"	1.6	1	3-WAY	1/2"	FLT	BELIMO	B309-LR24	LAST POS.
CUH-1	HW COIL	1	3/4"	2.5	1.5	2-WAY	1/2"	2-POS	ERIE	VT2212, AG13A020	NC
CUH-2	HW COIL	1	3/4"	2	1.2	2-WAY	1/2"	2-POS	ERIE	VT2212, AG13A020	NC
CUH-3	HW COIL	1	3/4"	2.5	1.5	2-WAY	1/2"	2-POS	ERIE	VT2212, AG13A020	NC
CUH-4	HW COIL	1	3/4"	3	1.8	2-WAY	1/2"	2-POS	ERIE	VT2212, AG13A020	NC
CUH-5	HW COIL	1	3/4"	3	1.8	2-WAY	1/2"	2-POS	ERIE	VT2212, AG13A020	NC
FP-1	RAD	29	3/4"	1	0.6	2-WAY	1/2"	2-POS	ERIE	VT2211, AG13A020	NC
C-1	RAD	1	3/4"	0.5	0.3	2-WAY	1/2"	2-POS	ERIE	VT2211, AG13A020	NC
C-2	RAD	1	3/4"	0.5	0.3	2-WAY	1/2"	2-POS	ERIE	VT2211, AG13A020	NC
C-3	RAD	1	3/4"	0.5	0.3	2-WAY	1/2"	2-POS	ERIE	VT2211, AG13A020	NC

B2 Two-way Characterized Control Valve, Stainless Steel Ball and Stem NM Actuators, MFT



Technical Data/Submittal

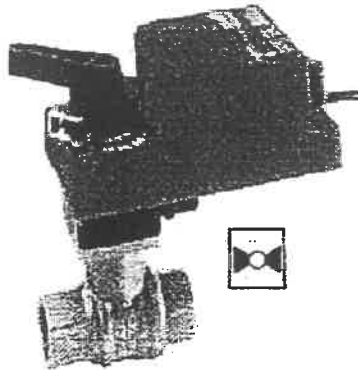

Application

This valve is typically used in air handling units on heating or cooling coils, and fan coil unit heating or cooling coils. Some other common applications include Unit Ventilators, VAV Box re-heat coils and bypass loops. This valve is suitable for use in a hydronic system with variable flow.

This valve is designed with MFT functionality which facilitates the use of various control input.

Valve Specifications

Service	chilled or hot water, 60% glycol	
Flow characteristic	A port equal percentage	
Action	Max 95° rotation	
Sizes	1-1/4" (B231) to 2" (B250)	
Type of end fitting	female, NPT	
Materials:		
Body	forged brass, nickel plated	
Ball	stainless steel	
Stem	stainless steel	
Seats	fiberglass reinforced teflon® PTFE	
Characterizing disc	TEFZEL®	
Packing	2 EPDM O-rings, lubricated	
Pressure rating	400 psi	
Media temp. range	0°F to 212°F [-18°C to 100°C]	
Close off pressure	200 psi	
Maximum differential pressure (ΔP)	Full flow version	on/off 150 psi (no A disc)
	Characterized A port modulating:	30 psi for quiet service, 50 psi maximum
Leakage	0%	
Cv rating	A port: see product chart for values	

tefzel® is a registered trademark of DuPont

Actuator Specifications

<input type="checkbox"/> NM24-MFT US	
Control	MFT
Control signal:	2 to 10 VDC
Power consumption:	1.3 W
Transformer sizing:	3.5 VA class 2 power source
Electrical connection:	3 ft. 18 GA plenum rated cable, 1/2" conduit fitting
Overload protection:	electronic throughout rotation
Input impedance:	100kΩ for 2 to 10 VDC (0.1 mA) 500kΩ for 4 to 20 mA 750kΩ for PWM 1500Ω for on/off and floating point
Feedback output:	2 to 10 VDC, 0.5 mA max
Angle of rotation:	95°
Direction or rotation:	L/R external switch
Position indication:	Indicator/handle
Manual override:	push button
Running time:	150 sec. independent of load (proportional)
Ambient temperature:	-4° F to 122° F [-20° C to 50° C]
Housing:	NEMA 2 / IP54
Housing material:	UL 94-5V (flammability rating)
Agency listings:	UL 873, CSA C22.2 No. 24 certified, CE
Quality standard:	ISO 9001
Noise level:	less than 35 dB(A)



P103611 5.1 3.1 01004-12V-11G. Subject to change. © Belimo Aircontrols U.S.A., Inc.

See Selection Chart Pg 118 for Control Valve No., Cv, and Close-off

Dimensions

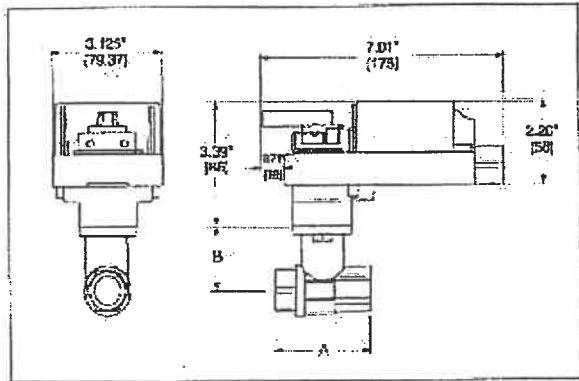

Nominal Valve Size		Dimensions in inches [mm]	
in	mm	A	B
1-1/4"	32	4.45 [113]	1.87 [48]
1-1/2"	40	4.31 [109.5]	1.88 [47.8]
2"	50	4.19 [106.4]	2.44 [62.0]

* On model numbers B232 and B231, the 1-1/4" valve has the same dimensions as a 1-1/2" valve. There are 1-1/2" valve bodies with 1-1/4" NPT threads.

Flow Pattern



Flow direction

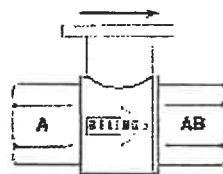

Wiring

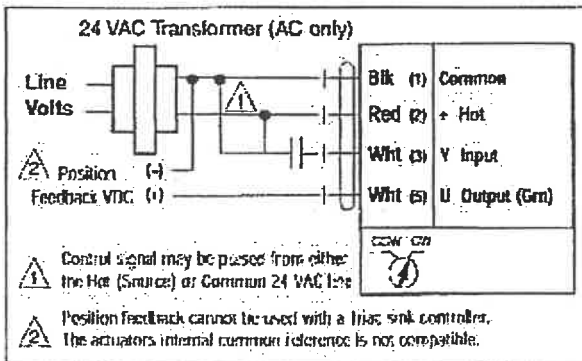

PWM, triac source and sink

Wiring

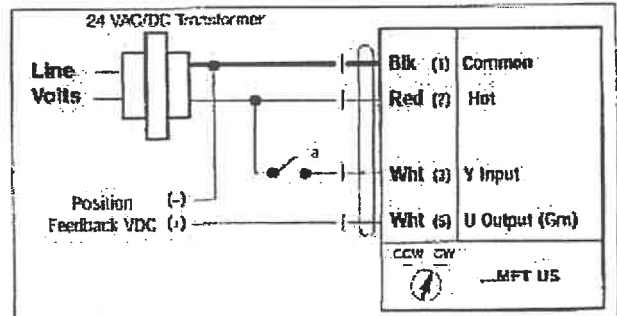

On-Off control

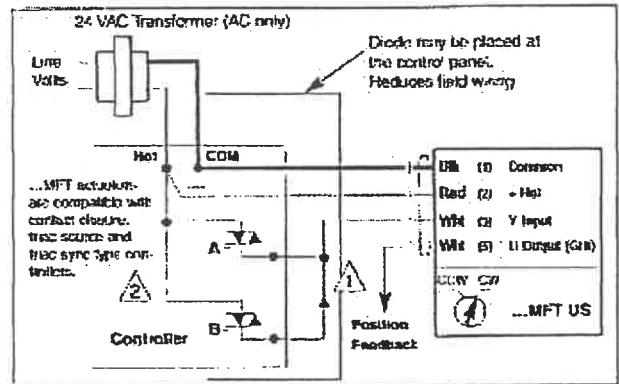

Floating Point control

1 R4804 or R4807 diode (R4807 supplied, Belimo part number 40155)
2 Triac A and B can also be contact closures.
Why is a diode required? The actuator is designed to recognize the rectified voltage as an opposite control signal request.

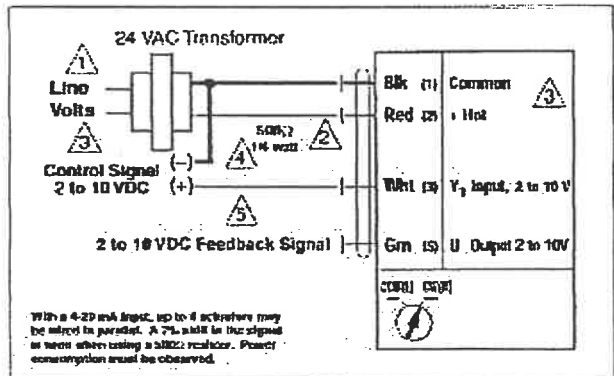

Proportional 2 to 10 VDC or 4 to 20 mA control signal

Notes

- 1 Provide overload protection and disconnect as required.
- 2 Actuators may be connected in parallel if not mechanically mounted to the same shaft. Power consumption and input impedance must be observed.
- 3 Actuator may also be powered by 24 VDC.
- 4 For 4-20 mA a 500Ω resistor is required.
- 5 ZG-R01 may be used.

© 2016 Belimo Inc. All rights reserved. Subject to change. Belimo Controls (USA) Inc.

B2 Series Characterized Control Valve,™ Non-Spring Return Actuator

Two-way Valve with Stainless Steel Ball and Stem

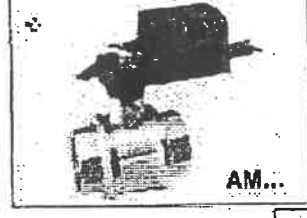
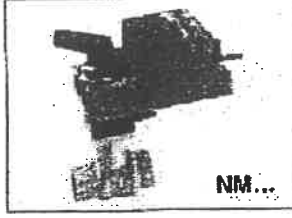
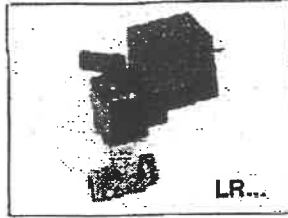
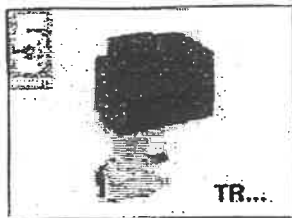

See page reference for Technical Data

Valve					Non-Spring Return Actuator				
Model # Cv Valve	Cv Rating	Valve Nominal Size		Close- Off psl	On/Off, Floating	On/Off, Floating	Proportional	Proportional	Proportional /MFT
		Inches	DN mm		TR24-3-T US	LR24 US LR24-S US NM24 US AM24 US	LR24-SR-1-2.0 US TR24-SR-T US†	LR24-SR-2.0 US NM24-SR US	LR24-MFT US NM24-MFT US AM24-MFT US
B207	0.3	1/2"	15	200	□ Pg 104	□ Pg 108	□ Pg 110/108	□ Pg 110	□ Pg 112
B208	0.46	1/2"	15	200	□ Pg 104	□ Pg 108	□ Pg 110/106	□ Pg 110	□ Pg 112
B209	0.8	1/2"	15	200	□ Pg 104	□ Pg 108	□ Pg 110/106	□ Pg 110	□ Pg 112
B210	1.2	1/2"	15	200	□ Pg 104	□ Pg 108	□ Pg 110/106	□ Pg 110	□ Pg 112
B211	1.9	1/2"	15	200	□ Pg 104	□ Pg 108	□ Pg 110/106	□ Pg 110	□ Pg 112
B212	3.0	1/2"	15	200	□ Pg 104	□ Pg 108	□ Pg 110/106	□ Pg 110	□ Pg 112
B213	4.7	1/2"	15	200	□ Pg 104	□ Pg 108	□ Pg 110/106	□ Pg 110	□ Pg 112
B214	7.4	1/2"	15	200	□ Pg 104	□ Pg 108	□ Pg 110/106	□ Pg 110	□ Pg 112
B215*	10	1/2"	15	200	□ Pg 104	□ Pg 108	□ Pg 110/106	□ Pg 110	□ Pg 112
B217	4.7	3/4"	20	200		□ Pg 108		□ Pg 110	□ Pg 112
B218	7.4	3/4"	20	200		□ Pg 108		□ Pg 110	□ Pg 112
B219	10	3/4"	20	200		□ Pg 108		□ Pg 110	□ Pg 112
B220*	24	3/4"	20	200		□ Pg 108		□ Pg 110	□ Pg 112
B222	7.4	1"	25	200		□ Pg 108		□ Pg 110	□ Pg 112
B223	10	1"	25	200		□ Pg 108		□ Pg 110	□ Pg 112
B224	19	1"	25	200		□ Pg 108		□ Pg 110	□ Pg 112
B225*	30	1"	25	200		□ Pg 108		□ Pg 110	□ Pg 112
B229	10	1-1/4"	32	200		□ Pg 108		□ Pg 110	□ Pg 112
B230*	19	1-1/4"	32	200		□ Pg 108		□ Pg 110	□ Pg 112
B231	25	1-1/4"	32	200		□ Pg 114		□ Pg 116	□ Pg 118
B232*	37	1-1/4"	32	200		□ Pg 114		□ Pg 116	□ Pg 118
B238	19	1-1/2"	40	200		□ Pg 114		□ Pg 116	□ Pg 118
B239	29	1-1/2"	40	200		□ Pg 114		□ Pg 116	□ Pg 118
B240*	37	1-1/2"	40	200		□ Pg 114		□ Pg 116	□ Pg 118
B248	29	2"	50	200		□ Pg 114		□ Pg 116	□ Pg 118
B249	46	2"	50	200		□ Pg 114		□ Pg 116	□ Pg 118
B250*	57	2"	50	200		□ Pg 114		□ Pg 116	□ Pg 118
B251	65	2"	50	100		□ Pg 120			□ Pg 122
B252	90	2"	50	100		□ Pg 120			□ Pg 122
B253	130	2"	50	100		□ Pg 120			□ Pg 122
B254*	265	2"	50	100		□ Pg 120			□ Pg 122
B261	65	2.5"	65	100		□ Pg 120			□ Pg 122
B262	90	2.5"	65	100		□ Pg 120			□ Pg 122
B263	130	2.5"	65	100		□ Pg 120			□ Pg 122
B264	180	2.5"	65	100		□ Pg 120			□ Pg 122
B265*	265	2.5"	65	100		□ Pg 120			□ Pg 122
B277	90	3"	80	100		□ Pg 120			□ Pg 122
B278	180	3"	80	100		□ Pg 120			□ Pg 122
B279	220	3"	80	100		□ Pg 120			□ Pg 122
B280*	265	3"	80	100		□ Pg 120			□ Pg 122
Electrical Connection					Covered Terminal Strip	3 ft cable, 1/2" conduit fitting	Covered Terminal Strip (TR) 3 ft Cable (LR)	3 ft cable, 1/2" conduit fitting	3 ft cable, 1/2" conduit fitting

* Models without characterizing desc. † TR24-SR-T US will be available in July 2004 and will replace the LR24-SR-1-2.0 US.

Options	TR24-3-T US TR24-SR-T US	LR24-S US □ Pg 108	LR24-SR-2.0 US	NM24 US NM24-SR US NM24-MFT US	AM24 US AM24-MFT US
Built-in aux. switch	LH...S US			□ Pg 197	□ Pg 198
Add-on aux. switch					
3-foot cable	TR...200 US, LR...200 US	□ Pg 104/106			
6-foot cable	TR...200 US, LR...200 US	□ Pg 104/106	□ Pg 108	□ Pg 110	
10-foot cable	TR...200 US, LR...200 US	□ Pg 104/106	□ Pg 108	□ Pg 110	
weather shield			□ Pg 199	□ Pg 198	□ Pg 198

© 2003 BELIMO North America, Inc. All rights reserved. BELIMO is a registered trademark of BELIMO North America, Inc.

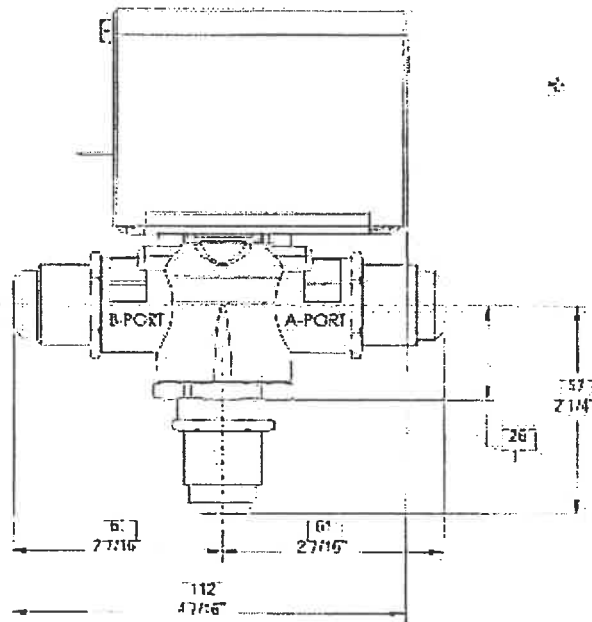

Figure-10 SAE - High Close-Off Style Actuator Shown

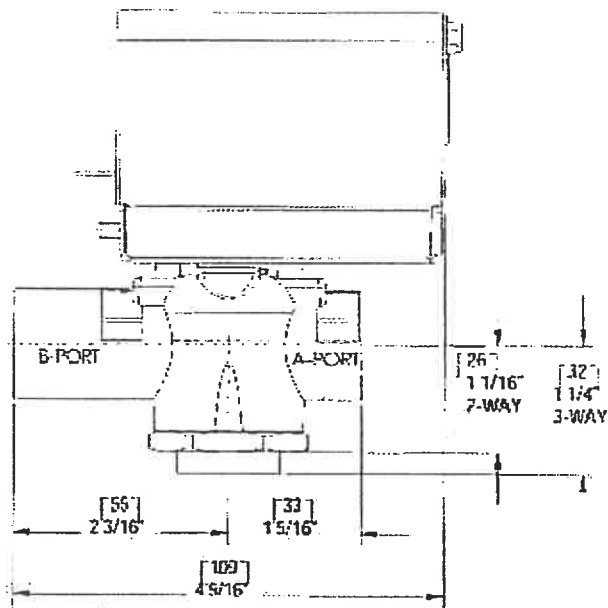

Figure-11 Inverted Flare - General Close-Off Style Actuator Shown

All specifications are nominal and may change as design improvements are introduced. Invenys Building Systems shall not be liable for damages resulting from misapplication or misuse of its products.

The following trademarks are the property of Invenys:

Invenys
Erie
PopTop

Part Numbering System Two Position Zone Valves, Spring Return Actuators

V X X X X X X X X X X X X X X

Body Type & Temperature
 T = On/Off (General)
 S = On/Off (Steam)
 High temperature actuator must be used.

Configuration
 2 = 2-Way
 3 = 3-Way

Valve Size
 2 = 1/2"
 3 = 3/4"
 4 = 1"
 6 = 1-1/4"

Connection Type	Availability
1 = Sweat	1/2", 3/4", 1", 1-1/4"
2 = Threaded NPT	1/2", 3/4", 1"
3 = Threaded Rp (metric)	1/2", 3/4", 1"
4 = Inverted Flare (Retrol)	3/4"
5 = SAE Flare	1/2"

Options
 0 = No Options
 A = End Switch

Electrical Leads
 00 = 6" Motor Wires
 01 = Terminal Block with End Switch (General Temp., 24 VAC only)
 02 = 10" (Standard) Wire Leads

Voltage
 A = 24 VAC, 50/60 HZ
 B = 110/120 VAC, 50/60 HZ
 D = 208 VAC, 50/60 HZ
 T = 277 VAC, 50/60 HZ
 H = 230 VAC, 50 HZ

Temperature Ratings
 3 = General Temperature
 4 = High Temperature

Spring Return	Availability
1 = Normally Closed	2-way and 3-way
2 = Normally Open	2-way only

Actuator Type
 G = On/Off (General Close-Off)
 H = On/Off (High Close-off)

CV Size				
No.	2-way	3-way	Size	Connection Type
1	1.0	1.5	1/2"	1, 2, 3, 5
			3/4"	4
2	2.5	3.0	1/2"	1, 2, 3, 5
			3/4"	1, 2, 3, 4
3	3.5	4.0	1/2"	1, 2, 3, 5
			3/4"	1, 2, 3, 4
5	5.0	5.0	3/4"	1, 2, 3
			1"	1
7	7.5	7.5	3/4"	1, 2, 3
			1"	1, 2, 3
				1-1/4"

1. When ordering valve body only: use the first six positions to configure the valve.
2. When ordering actuator only use the last seven positions to configure the actuator. Prefix with the letter "A".
3. Invensys inverted flare fittings must be ordered separately. See actuator accessories for fitting part numbers.
4. End switch is only available if actuator temperature rating is general (3).
5. Actuators with Terminal blocks require endswitch and the endswitch is 24 V/5A.
6. End switch is 240V/5A max for actuators rated 240V or less. End switch is 277V/5A max for actuators rated 277V.

Body & Actuator Combination Requirements

Temperature Configurations	
Body Configuration V T X X X X T = General S = Steam If body configuration is T, actuator temp rating can be 3 or 4. If body configuration is S, actuator temp rating must be 4.	Actuator Spring Return Mode A X X 3 X X X X 3 = General Temperature 4 = High Temperature If actuator temp rating is 3, body style must be T. If actuator temp rating is 4, body style can be S or T.

Example
 Assembly: VT2213G13A020. Components: VT2213 = Body, AG13A020 = Actuator.
 The actuator part number is prefixed with the letter "A".

TYPICAL APPLICATION (wiring diagram)

Honeywell - Wire Leads

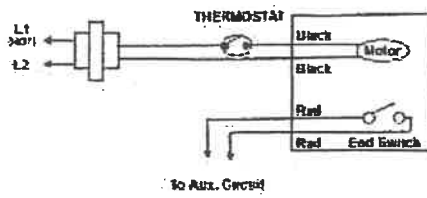

Honeywell - Terminal Block

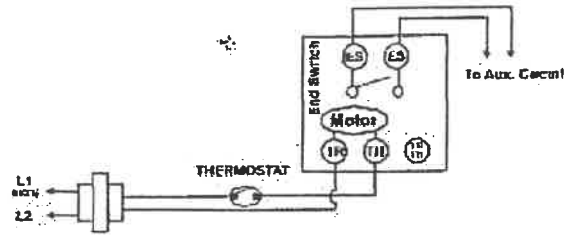

Invensys - Erie Wire Leads

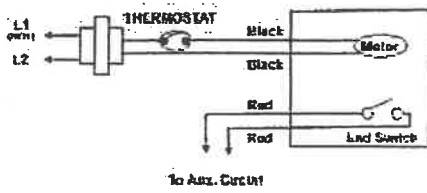

Invensys - Erie Terminal Block

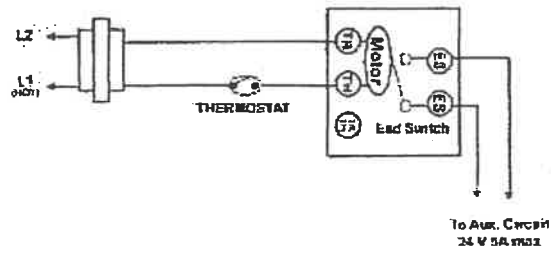
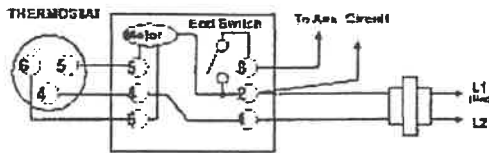
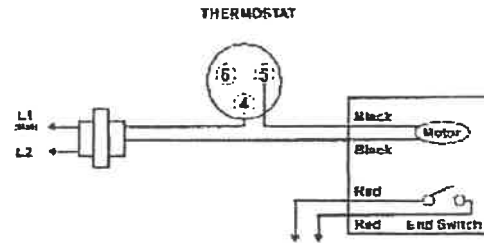

Figure-1 Typical Wiring of a PopTop to Replace a Honeywell Valve

White - Rodgers (1311 or 1321)



Invensys - Erie Wire Leads



Invensys - Erie Terminal Block

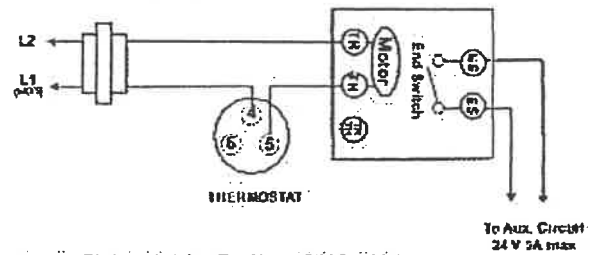
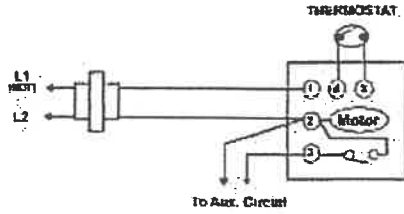
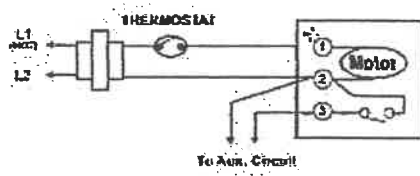

Figure-2 Typical Wiring of a PopTop to Replace a Flair or White-Rodgers 3-Wire Valve

Flair - Terminal Block



Taco - Terminal Block



Invensys - Erie Wire Leads

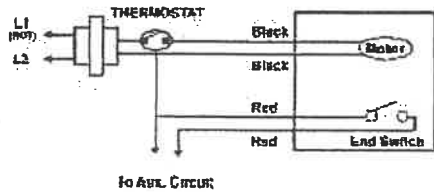

Invensys - Erie Wire Leads

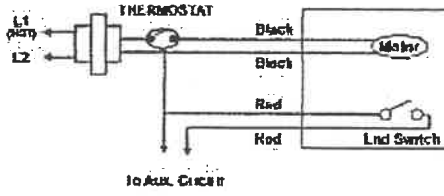

Invensys - Erie Terminal Block

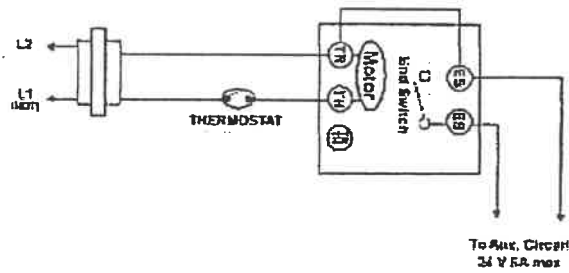

Figure-3 Typical Wiring of a PopTop to Replace a Flair or Taco 3-Wire Valve

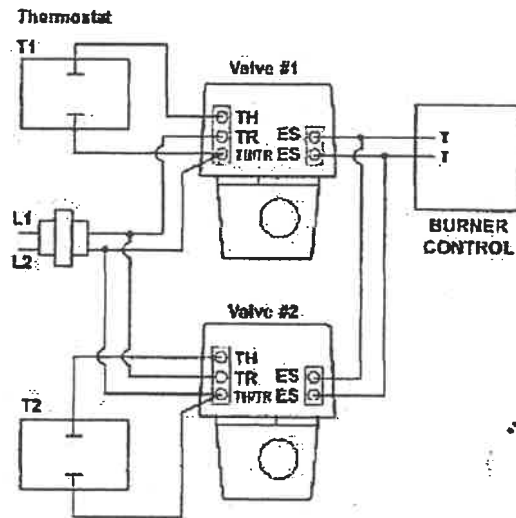

Figure-4 Typical Multiple Valve Wiring